

# Liquid Fuels from U.S. Coal

*The technology is modern, proven and ready . . . It has national security, economic and environmental benefits . . . What is needed to make it happen?*

A recent ABC News poll reported a majority of Americans believe rising gasoline prices are causing personal financial hardships and are a potential threat to the long-term durability of the U.S. economy.

This spring, gasoline prices increased at the fastest rate in 50 years.

Recent natural disasters have caused disruption at up to a dozen refineries in the U.S. . . . at a time when America is dependent on foreign sources of petroleum for 56 percent of its needs - a share that will grow to nearly 70 percent by 2025 if nothing changes, according to the Energy Information Administration (EIA).

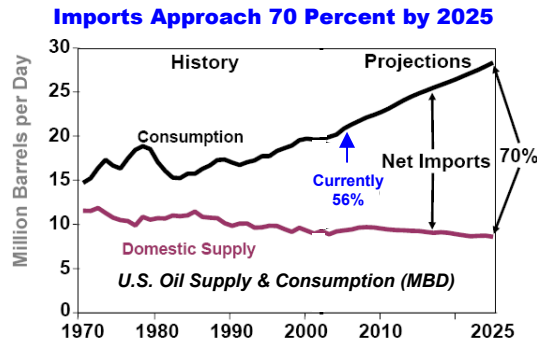

*U.S. dependency on imported oil will grow to nearly 70 percent by 2025, according to EIA.*

There is a solution to these and other problems related to the nation's critical need for a reliable and affordable supply of liquid fuel - *America's abundant and readily available supplies of domestic coal*. Consider these facts:

## U.S. Reserves / Production Ratio Years Supply at Current Production

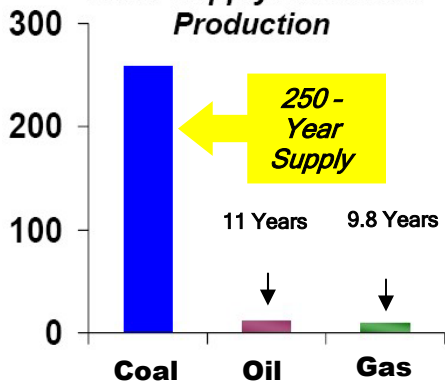

SOURCE: EIA, BP Statistical Review of Energy

- There are more than 250 billion tons of recoverable U.S. coal reserves - equivalent to an estimated 800 billion barrels\* of oil (compared to Saudi Arabia's proven reserves of 260 billion barrels).
- Coal already provides more than half of the nation's electricity and is the largest single source of overall domestic energy production at more than 31 percent of the total.
- Coal can be converted through proven, existing modern technology into clean, zero-sulfur synthetic oil and oil products at a cost of approximately \$35 per barrel - compared to the current world price of about \$67 per barrel for oil.
- Coal is a 21<sup>st</sup> century energy resource - it is mined, transported and used in the U.S. in an environmentally compatible and sustainable manner.
- Unlike other energy resources, the location and quantity of U.S. coal reserves are known and mapped - exploration isn't necessary.

\*(Source: Oil and gas data: EIA, Advance Summary U.S. Crude Oil, Natural Gas and Natural Gas Liquids Reserves, 2003 Annual Report; BP Statistical Review of Energy; contained in presentation, "Coal & Liquid Fuels," by Richard Bajura, Edward Eyring, presented at the GCEP Advanced Coal Workshop, March 15-16, 2004, Provo, Utah).

*Given these advantages, why isn't coal-to-liquid fuels a reality?  
Why are there no commercial coal-to-liquid plants in the U.S. today?*

One reason is the historic *sharp volatility of oil prices* - if the price of oil stays above \$35 per barrel, a coal refinery makes economic sense. If it drops below that figure, as it has in the past (see graph at right), there is no assurance a coal refinery can remain competitive, posing a substantial risk for investors.

Secondly, the *front end cost is high* - coal refineries are expensive to construct, with capital costs in the \$600-million-to-\$700-million range for a 10,000 barrel per day plant, according to FT Solutions LLC. The technical and financial risks of a "first of a kind" plant in the United States have discouraged consideration of this type of investment in the past.

Finally, the *lead time* for a coal refinery, as with all refineries, is a minimum of five to seven years under optimal circumstances.

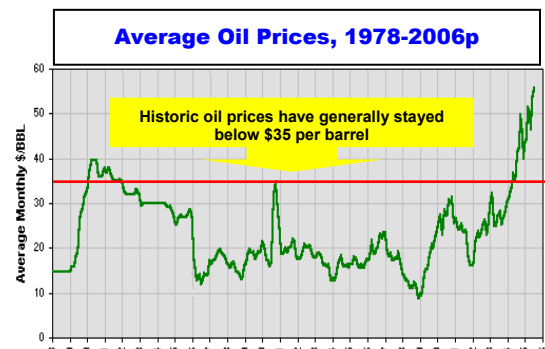

SOURCE: [www.oilenergy.com](http://www.oilenergy.com); p = projected

*But steps can be taken to create incentives and minimize these disadvantages so that Americans could be using domestic-based coal-to-liquid fuels in the near future - if we act soon.*

## Producing Liquid Fuels from Coal - Two Approaches

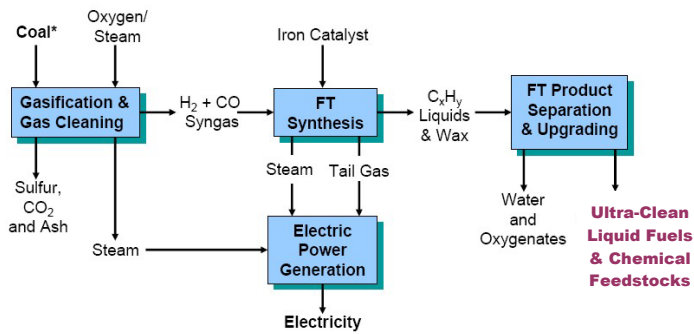

*One method of producing liquid fuels from coal is the Fischer-Tropsch indirect liquefaction process, which yields high quality transportation fuels, among other products (SOURCE: FT Solutions LLC).*

Coal-to-liquid fuel technologies are well-established and have been *improved by 30 years of U.S. government research and development efforts*, directly and through industry partnerships, into innovative processes ready for widespread commercialization in the 21<sup>st</sup> century.

Technology has come a long way since the first coal-derived liquid fuel (a synthetic crude oil) was produced through direct liquefaction in the early 1900s. In 1925, **Franz Fischer** and **Hans Tropsch** used an indirect liquefaction process, which still bears their name, to produce excellent transportation fuels. Germany had 25 liquefaction plants that, at their peak in 1944, produced more than 124,000 barrels daily and met 90 percent of the nation's needs.

In the 1950s, South Africa, through its **SASOL Co.**, developed a commercial coal liquids industry to produce transportation fuels (gasoline and diesel) using synthesis gas produced by the gasification of coal. Modern research has further developed this technology, and SASOL has produced more than 700 million barrels of synthetic fuels from coal since the early 1980s. About 85 percent of the coal consumed in South Africa is used as synfuels feedstock or to produce electricity.

The U.S. government, directly and through industrial partnerships and international cooperation, has a 30-year research effort that has *resulted in improved processes, catalysts and reactors. These improvements have helped reduce costs and improved product quantity and quality.*



*Coal liquefaction is proven technology that has been enhanced by modern research. South Africa's SASOL Co. developed a commercial coal liquids industry that produces about 150,000 barrels daily at its Secunda plant.*

While the stage is set for rapid commercialization and deployment in the U.S., **China** - with its vast coal reserves and immensely growing economy - currently **is ahead of America in this regard.**



*Concerned about increasing dependence on oil imports and its impact on economic growth and national security, China is making a massive \$6 billion investment in new coal liquefaction plants. At left is the planned \$2 billion Shenhua facility, which is expected to open in October 2007 in Inner Mongolia and eventually produce 50,000 barrels daily of diesel fuel and gasoline.*

Source: "Coal to Clean Fuel" presentation by Jerald J. Fletcher and Qingyun Sun, West Virginia University, at the 3<sup>rd</sup> U.S.-China Clean Energy Workshop, Oct. 18-19, 2004.

China, which is the world's second biggest consumer and importer of oil after the U.S., is planning a *\$6 billion investment in new liquefaction plants that would have a total annual production capacity of 440 million barrels of liquid fuel annually*, dwarfing those of SASOL's plants in South Africa, according to UtiliPoint International Inc. A facility planned for Mongolia (and based primarily on U.S.-developed technology) will come on line in this decade and eventually produce 50,000 barrels daily of clean-burning gasoline and diesel fuel.

### Advantages of Coal-to-Liquid Fuels

- Improves national and economic security by lessening dependence on foreign oil and substituting plentiful, more affordable U.S. coal.
- Uses domestic resources and produces more jobs for Americans.
- Provides positive influence on U.S. balance of trade and economy.
- Provides environmental benefits, including cleaner fuels that reduce nitrogen oxide and particulate emissions, enabling use of higher efficiency engines.
- Is capable of capturing carbon dioxide (CO<sub>2</sub>) emissions and serving as a bridge to a hydrogen fuel future through polygeneration (linking multiple types of plants into one, such as co-production of liquid fuels, electricity, hydrogen, etc., embodied in FutureGen initiative).
- Provides geographic diversity of domestic refining capacity (Coal is located in 38 states and all regions of the U.S.).

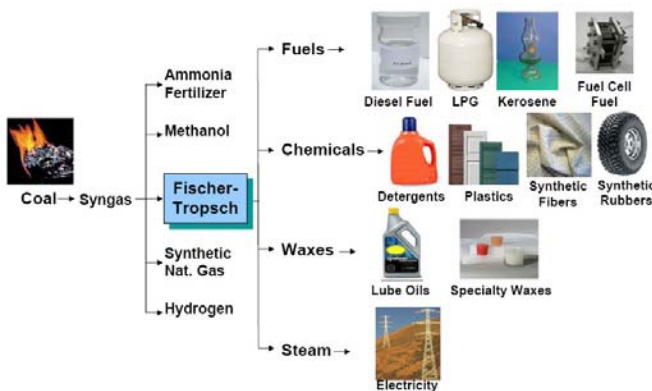

---

*In addition to synthetic oil and diesel fuels, numerous additional liquid products can be derived from coal, including these examples from the Fischer-Tropsch indirect liquefaction process.*

Source: FT Solutions LLC

---

### What is Needed to Make it Happen in the U.S.?

Although existing impediments to wide scale deployment of coal-to-liquids technologies are challenging, all can be mitigated or eliminated through concerted and focused efforts by government and industry and with public support. For example:

- Construction of new coal-to-liquids capacity can be made more attractive with incentives, such as streamlining the permitting process; offering federal loan guarantees to cover construction costs; providing federal financing to pay charges incurred through permitting delays; and offering price guarantees, or providing a price floor, for refinery output.
- Tax incentives, such as federal investment tax credits, fuel excise tax exemptions or accelerated depreciation could be used to reduce risk and assist commercial development.
- Siting issues can be mitigated by maximizing retrofit opportunities at existing coal-based power plants or by placing refineries on closed military bases or abandoned industrial or mine sites.
- State/federal government partnership consortiums with industry to build first-of-a-kind, commercial-scale demonstration facilities that use advanced technologies.

Incentives such as these would get the ball rolling. Eventually, market forces would take over, and the private sector would assume the majority of risks for commercialization and technology deployment. China is putting billions of dollars into its coal-to-liquids fuels program: the failure of the U.S. to provide domestic incentives could prove to be a significant energy, economic, environmental and security challenge later in this century.

**Congress should adopt incentives  
for coal-to-liquid fuel facilities!**