

Cahier technique no. 18

Analysis of three-phase networks
in disturbed operating conditions
using symmetrical components

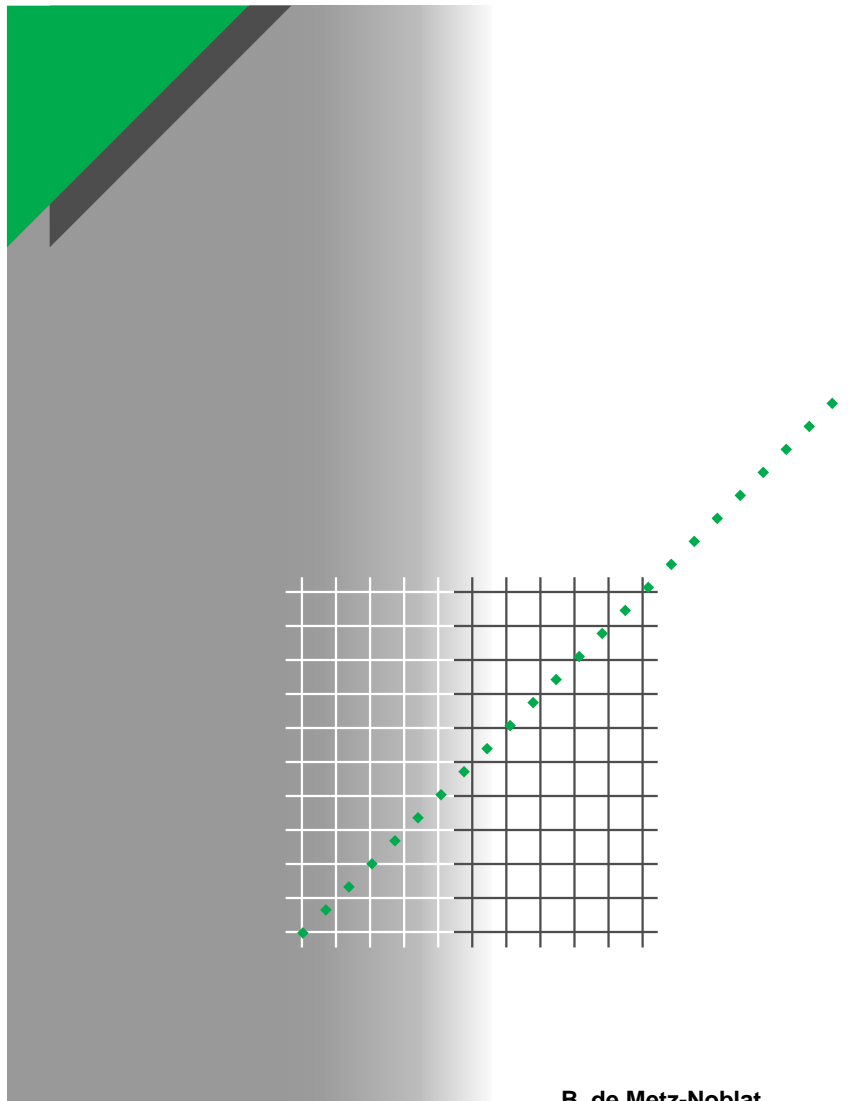

B. de Metz-Noblat

"Cahiers Techniques" is a collection of documents intended for engineers and technicians, people in the industry who are looking for more in-depth information in order to complement that given in product catalogues.

Furthermore, these "Cahiers Techniques" are often considered as helpful "tools" for training courses.

They provide knowledge on new technical and technological developments in the electrotechnical field and electronics. They also provide better understanding of various phenomena observed in electrical installations, systems and equipments.

Each "Cahier Technique" provides an in-depth study of a precise subject in the fields of electrical networks, protection devices, monitoring and control and industrial automation systems.

The latest publications can be downloaded from the Schneider Electric internet web site.

Code: <http://www.schneider-electric.com>

Section: **Press**

Please contact your Schneider Electric representative if you want either a "Cahier Technique" or the list of available titles.

The "Cahiers Techniques" collection is part of the Schneider Electric's "Collection technique".

Foreword

The author disclaims all responsibility subsequent to incorrect use of information or diagrams reproduced in this document, and cannot be held responsible for any errors or oversights, or for the consequences of using information and diagrams contained in this document.

Reproduction of all or part of a "Cahier Technique" is authorised with the compulsory mention:

"Extracted from Schneider Electric "Cahier Technique" no." (please specify).

no. 18

Analysis of three-phase networks in disturbed operating conditions using symmetrical components



Benoît de METZ-NOBLAT

A graduate engineer from ESE (Ecole Supérieure d'Electricité), he worked for the Saint-Gobain group before joining Merlin Gerin in 1986. Currently attached to the "Technology & Innovations" department, he is a member of the "Electrical Networks" working group, which is responsible for studying electrical phenomena relating to the operation of networks and their interaction with equipment and devices.

Analysis of three-phase networks in disturbed operating conditions using symmetrical components

The dimensioning of an installation and the equipment to be used, the settings for the protection devices, and the analysis of electrical phenomena often require calculation of the currents and voltages in electrical networks.

The purpose of this “Cahier Technique” is to set out a simple method of calculating all these parameters in three-phase networks subject to disturbance using the symmetrical components method, and to provide specific application examples.

Contents

1 Introduction		p. 4
2 Brief review of vector mathematics	2.1 Vector representation of a physical phenomenon	p. 5
	2.2 Basic definition	p. 5
	2.3 Vector representation	p. 6
	2.4 Symmetrical components	p. 7
	2.5 Analysis of a three-phase system into its symmetrical components	p. 8
	2.6 Mathematical calculation of the symmetrical components	p. 9
	2.7 Conclusion: Relevance to electrical engineering	p. 10
3 Basic applications	3.1 Method of calculating unbalanced states	p. 11
	3.2 Phase-to-ground fault (zero-sequence fault)	p. 12
	3.3 Two-phase to ground fault	p. 13
	3.4 Three-phase fault	p. 14
	3.5 Network with an unbalanced load	p. 15
	3.6 Network with one open phase	p. 16
	3.7 Impedances associated with symmetrical components	p. 17
	3.8 Summary formulae	p. 19
4 Worked examples	4.1 Breaking capacity of a circuit-breaker at the supply end	p. 20
	4.2 Breaking capacity of circuit-breakers at the ends of a line	p. 21
	4.3 Settings for zero-sequence protection devices in a grounded neutral MV network	p. 24
	4.4 Settings for a protection device with a negative-sequence current in an electrical installation	p. 26
	4.5 Measuring the symmetrical components of a voltage and current system	p. 27
Appendix		p. 29

1 Introduction

In normal, balanced, symmetrical operation, the study of three-phase networks can be reduced to the study of an equivalent single-phase network with voltages equal to the phase to neutral voltages of the network, currents equal to those of the network and impedances equal to those of the network, known as **cyclic** impedances.

Asymmetrical operation can occur in a network if there is an unbalance in the voltage or impedance system of the electrical elements (due to a fault or by design).

If the asymmetry is significant, simplification is no longer possible because the relations in the various conductors cannot be determined by

means of a cyclic impedance for each element of the network.

The general method based on Ohm's and Kirchhoff's laws is possible, but it is complex and laborious.

The "symmetrical components" method described in this document simplifies the calculations and provides a much easier solution by reducing it to the superposition of three independent single-phase networks.

After a brief review of vector concepts, this method is explained by reference to basic applications on various types of short-circuit, followed by worked examples of actual cases.

2 Brief review of vector mathematics

2.1 Vector representation of a physical phenomenon

A vibrating physical phenomenon is sinusoidal when the elongation of a vibrating point is a sinusoidal time function:

$$x = a \cos(\omega t + \varphi).$$

The application to electrical engineering, in which voltages and currents are sinusoidal phenomena, is well known.

■ Consider a vector \vec{OM} with modulus a , rotating in the plane (\vec{Ox}, \vec{Oy}) about its origin O with a constant angular velocity ω (see Fig. 1).

If at starting time $t = 0$, the angle (\vec{Ox}, \vec{OM}) has the value φ , at time t it will have the value $(\omega t + \varphi)$.

We can project the current vector \vec{OM} onto the \vec{Ox} axis.

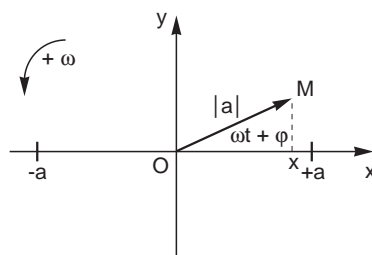

Fig. 1

At time t , the algebraic value of its projection is: $x = a \cos(\omega t + \varphi)$. Thus:

□ The movement of the projection of the end of the vector rotating about the \vec{Ox} axis is a sinusoidal movement with amplitude a equal to the modulus of this vector.

□ The angular frequency ω of the sinusoidal movement is equal to the angular velocity of the rotating vector.

□ The initial phase φ is equal to the angle made by the rotating vector with the \vec{Ox} axis at starting time $t = 0$.

■ In the same way, a rotating vector can be made to correspond to any sine function $x = a \cos(\omega t + \varphi)$.

The function x is conventionally represented by the vector \vec{OM} in the position which it occupies at starting time $t = 0$; the modulus of the vector represents amplitude a of the sine function and the angle (\vec{Ox}, \vec{OM}) represents its starting phase.

■ The study of a sinusoidal physical phenomenon can therefore be reduced to the study of its corresponding vector. This is useful because mathematical manipulation on vectors is relatively straightforward.

This applies in particular to three-phase electrical phenomena in which voltages and currents are represented by rotating vectors.

2.2 Basic definition

■ Consider a sinusoidal vibrating electrical phenomenon represented by a rotating vector \vec{V} (see Fig. 2).

This is in principle as follows:

■ A reference axis \vec{Ox} of unit vector \vec{x} : $|\vec{x}| = 1$.

■ A direction of rotation conventionally defined as positive in the anti-clockwise direction \curvearrowright .

■ The vector \vec{V} whose origin is reduced to O is essentially characterized by:

□ An amplitude \vec{V} : At a given time the length of the vector is numerically equal to the modulus of the size of the phenomenon.

□ A phase φ : At a given time this is the angle (\vec{Ox}, \vec{V}) made by \vec{V} with the reference axis \vec{Ox} , taking into account the adopted direction of rotation.

□ An angular frequency: This is the constant speed of rotation of the vector in radians per second.

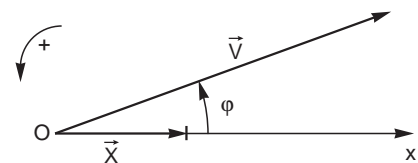

Fig. 2

This is commonly expressed in revolutions per second, in which case it is the frequency of the phenomenon in Hz ($1 \text{ Hz} = 2\pi \text{ rd/s}$).

■ A three-phase system is a set of 3 vectors $\vec{V}_1, \vec{V}_2, \vec{V}_3$, with the same origin, the same angular frequency and each with a constant amplitude.

■ An electrical system is linear when there is a proportionality in the relations of causes to effects.

2.3 Vector representation

The vector \vec{V} is traditionally represented in a system of rectangular coordinate axes (see Fig. 3).

$$\vec{V} = \vec{OM} = \vec{OX} + \vec{OY} = \vec{OX} \vec{x} + \vec{OY} \vec{y}$$

■ Operator "j"

To simplify operations on the vectors, \vec{V} can be represented in an equivalent way by a complex number using the operator "j".

"j" is a vector operator which rotates the vector to which the operation is applied through $+\pi/2$, in other words $j\vec{x} = \vec{y}$.

Thus we can see that:

$$j^2 = -1 \text{ (rotation of } 2\frac{\pi}{2} = \pi)$$

$$j^3 = -j \text{ (rotation of } 3\frac{\pi}{2} = \frac{3\pi}{2})$$

$$j^4 = +1 \text{ (rotation of } 4\frac{\pi}{2} = 2\pi)$$

hence:

$$\vec{V} = \vec{OX} \vec{x} + \vec{OY} j\vec{x} = \vec{x} (\vec{OX} + j \vec{OY})$$

■ Operator "a"

"a" is a vector operator which rotates the vector to which the operation is applied through $+2\pi/3$ (see Fig. 4).

Thus we can see that:

□ a^2 rotates a vector by:

$$2 \frac{2\pi}{3} = \frac{4\pi}{3} \text{ (equivalent to } -\frac{2\pi}{3})$$

□ a^3 rotates a vector by:

$$3 \frac{2\pi}{3} = 2\pi \text{ (equivalent to } 0)$$

$$a = -0.5 + j\frac{\sqrt{3}}{2}$$

$$a^2 = -0.5 - j\frac{\sqrt{3}}{2}$$

so

$$a^0 = a^3 = a^6 \dots = 1$$

$$a = a^4 = a^7 \dots \quad a^2 = a^{-2} = a^{-5} \dots$$

$$a - a^2 = j\sqrt{3} \quad \text{and} \quad 1 + a + a^2 = 0$$

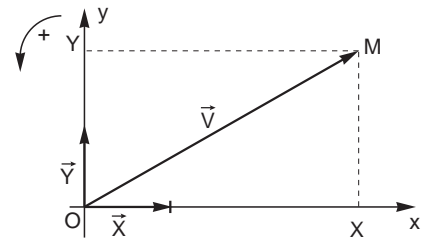

Fig. 3

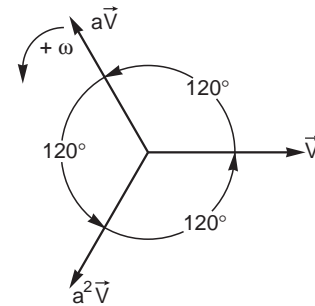

Fig. 4

This last relation can be verified graphically from the figure, where we can see that the sum of the vectors shown is zero:

$$\vec{V} + a\vec{V} + a^2\vec{V} = 0$$

$$\text{so } \vec{V}(1 + a + a^2) = 0$$

$$\text{therefore } 1 + a + a^2 = 0$$

2.4 Symmetrical components

Consider a set of three sinusoidal three-phase vectors rotating at the same speed. They are therefore fixed in relation to one another.

There are three specific arrangements in which the vectors are symmetrical to one another and which are therefore known as “symmetrical components”:

■ The “positive-sequence” system (see Fig. 5), in which $\vec{V}_1, \vec{V}_2, \vec{V}_3$

- have the same amplitude
- are shifted by 120°
- are arranged such that an observer at rest sees the vectors pass by in the order

$$\vec{V}_1, \vec{V}_2, \vec{V}_3;$$

$$\vec{V}_1$$

$$\vec{V}_2 = a^2 \vec{V}_1 = a \vec{V}_3$$

$$\vec{V}_3 = a \vec{V}_1$$

■ The “negative-sequence” system (see Fig. 6), in which $\vec{V}_1, \vec{V}_2, \vec{V}_3$

- have the same amplitude
- are shifted by 120°
- are arranged such that an observer at rest sees the vectors pass by in the order

$$\vec{V}_1, \vec{V}_3, \vec{V}_2;$$

$$\vec{V}_1$$

$$\vec{V}_2 = a \vec{V}_1$$

$$\vec{V}_3 = a^2 \vec{V}_1 = a \vec{V}_2$$

■ The “zero-sequence” system (see Fig. 7), in which $\vec{V}_1, \vec{V}_2, \vec{V}_3$

- have the same amplitude
- are in phase and therefore co-linear, so an observer at rest sees them all pass by at the same time.

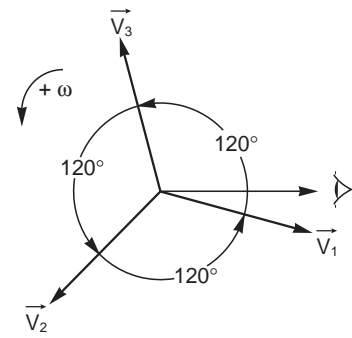

Fig. 5

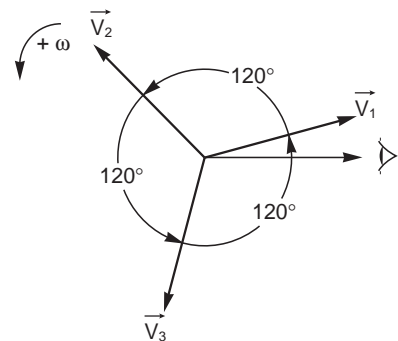

Fig. 6

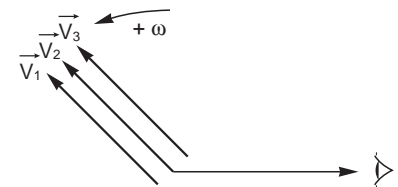

Fig. 7

2.5 Analysis of a three-phase system into its symmetrical components

Consider any three-phase system formed from three vectors $\vec{V}_1, \vec{V}_2, \vec{V}_3$ (see basic definitions); we can show that this system is the sum of three balanced three-phase systems:

Positive-sequence, negative-sequence and zero-sequence.

- Positive-sequence system: $\vec{V}_{d1}, \vec{V}_{d2}, \vec{V}_{d3}$
- Negative-sequence system: $\vec{V}_{i1}, \vec{V}_{i2}, \vec{V}_{i3}$
- Zero-sequence system: $\vec{V}_{o1}, \vec{V}_{o2}, \vec{V}_{o3}$

This gives:

$$\vec{V}_1 = \vec{V}_{d1} + \vec{V}_{i1} + \vec{V}_{o1}$$

$$\vec{V}_2 = \vec{V}_{d2} + \vec{V}_{i2} + \vec{V}_{o2}$$

$$\vec{V}_3 = \vec{V}_{d3} + \vec{V}_{i3} + \vec{V}_{o3}$$

If we choose the vectors with index 1 as origin vectors and apply the operator "a", we obtain the

following equations:

$$\vec{V}_1 = \vec{V}_d + \vec{V}_i + \vec{V}_o$$

$$\vec{V}_2 = a^2 \vec{V}_d + a \vec{V}_i + \vec{V}_o$$

$$\vec{V}_3 = a \vec{V}_d + a^2 \vec{V}_i + \vec{V}_o$$

We can calculate the symmetrical components:

$$\vec{V}_d = \frac{1}{3}(\vec{V}_1 + a \vec{V}_2 + a^2 \vec{V}_3)$$

$$\vec{V}_i = \frac{1}{3}(\vec{V}_1 + a^2 \vec{V}_2 + a \vec{V}_3)$$

$$\vec{V}_o = \frac{1}{3}(\vec{V}_1 + \vec{V}_2 + \vec{V}_3)$$

Their geometric construction is easy by taking into account the meaning of the operator "a" (rotation by $2\pi/3$) (see Fig. 8).

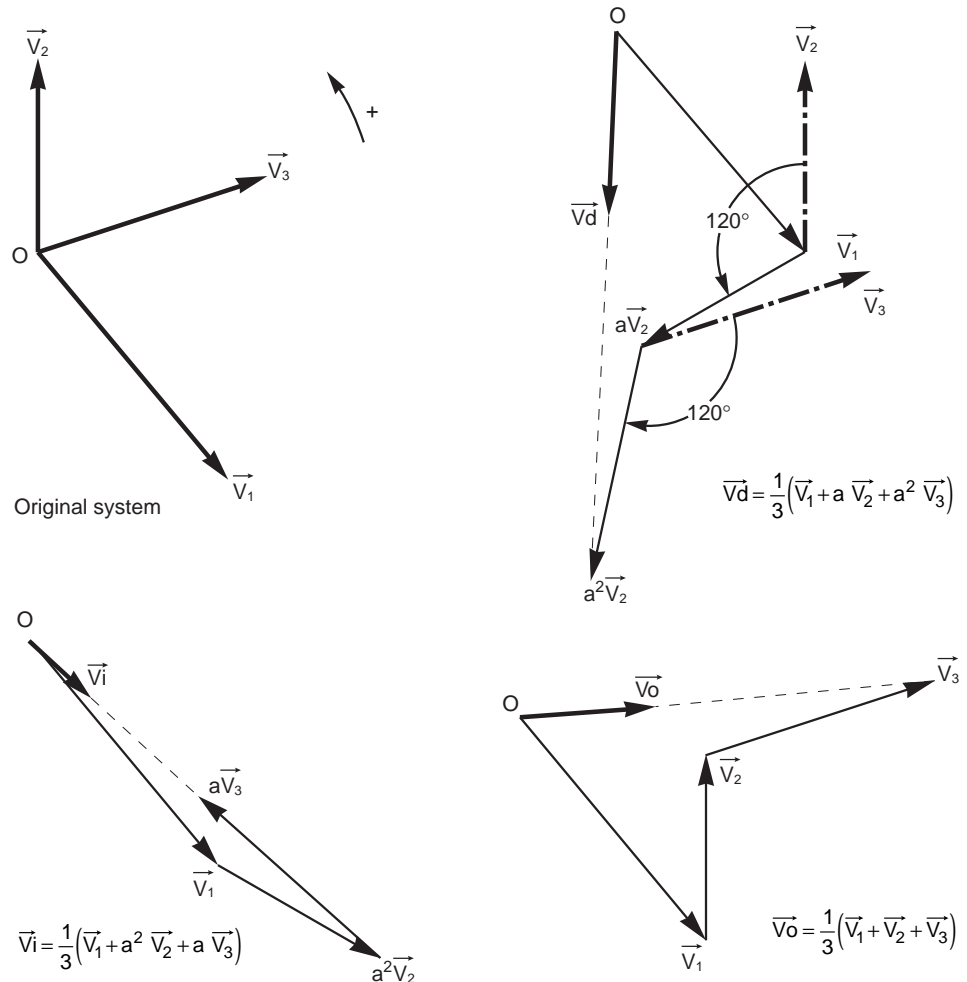

Fig. 8 : Geometric construction of symmetrical components with operator "a".

More practically, we can construct the symmetrical components directly on the figure without having to transfer vectors (see Fig. 9). Consider the points D and E such that BDCE is a rhombus composed of two equilateral triangles BDC and BCE and with O' as the barycenter of

the triangle ABC; a simple calculation (see paragraph below) shows that:

$$\vec{V}_d = \frac{\vec{E}\vec{A}}{3} \quad \vec{V}_i = \frac{\vec{D}\vec{A}}{3} \quad \vec{V}_o = \vec{O}\vec{O}'$$

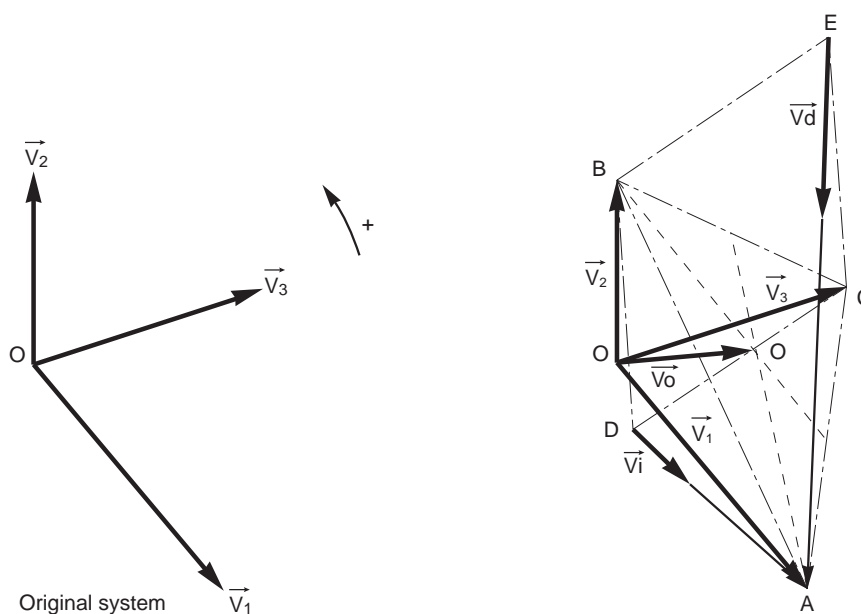

Fig. 9 : Geometric construction of symmetrical components on the three-phase system.

2.6 Mathematical calculation of the symmetrical components

Consider the points D and E such that (BDCE) is a rhombus composed of two equilateral triangles (BDC) and (BCE).

$\vec{E}\vec{A} = \vec{E}\vec{B} + \vec{B}\vec{A}$, thus $\vec{E}\vec{B} = a^2\vec{B}\vec{C}$ therefore

$$\begin{aligned} \vec{E}\vec{A} &= a^2\vec{B}\vec{C} + \vec{B}\vec{A} \\ &= a^2\vec{B}\vec{O} + a^2\vec{O}\vec{C} + \vec{B}\vec{O} + \vec{O}\vec{A} \\ &= \vec{O}\vec{A} + \vec{O}\vec{B}(-a^2 - 1) + a^2\vec{O}\vec{C} \\ &= \vec{O}\vec{A} + a\vec{O}\vec{B} + a^2\vec{O}\vec{C} \\ &= \vec{V}_1 + a\vec{V}_2 + a^2\vec{V}_3 = 3\vec{V}_d \end{aligned}$$

$$\vec{V}_d = \frac{\vec{E}\vec{A}}{3}$$

$\vec{D}\vec{A} = \vec{D}\vec{B} + \vec{B}\vec{A}$, thus $\vec{D}\vec{B} = a\vec{B}\vec{C}$ therefore

$$\begin{aligned} \vec{D}\vec{A} &= a\vec{B}\vec{C} + \vec{B}\vec{A} \\ &= a\vec{B}\vec{O} + a\vec{O}\vec{C} + \vec{B}\vec{O} + \vec{O}\vec{A} \\ &= \vec{O}\vec{A} + \vec{O}\vec{B}(-a - 1) + a\vec{O}\vec{C} \end{aligned}$$

$$\begin{aligned} \vec{D}\vec{A} &= \vec{O}\vec{A} + a^2\vec{O}\vec{B} + a\vec{O}\vec{C} \\ &= \vec{V}_1 + a^2\vec{V}_2 + a\vec{V}_3 = 3\vec{V}_i \end{aligned}$$

$$\vec{V}_i = \frac{\vec{D}\vec{A}}{3}$$

Let O' be the barycenter of triangle ABC, then

$$\begin{aligned} \vec{O}'\vec{A} + \vec{O}'\vec{B} + \vec{O}'\vec{C} &= 0 \\ \vec{V}_1 + \vec{V}_2 + \vec{V}_3 &= 3\vec{V}_o \\ &= \vec{O}\vec{A} + \vec{O}\vec{B} + \vec{O}\vec{C} \\ &= \vec{O}\vec{O}' + \vec{O}'\vec{A} + \vec{O}\vec{O}' + \vec{O}'\vec{B} + \vec{O}\vec{O}' + \vec{O}'\vec{C} \\ &= 3\vec{O}\vec{O}' + \vec{O}'\vec{A} + \vec{O}'\vec{B} + \vec{O}'\vec{C} \\ &= 3\vec{O}\vec{O}' \end{aligned}$$

$$\vec{V}_o = \vec{O}\vec{O}'$$

2.7 Conclusion: Relevance to electrical engineering

The method described in the previous section is directly relevant to electricity in the case of linear three-phase networks with a single frequency.

This is because three-phase systems applied to electrical networks can be unbalanced by load or fault asymmetries.

In addition, the simplicity provided by calculations reduced to the superposition of three independent systems, which are treated separately by reducing each to the simple single-phase case, is both practical and effective.

Note that these mathematical manipulations correspond well to a physical reality of the phenomena: the symmetrical impedances of the electrical equipment can be measured (see chapter 3), as can the symmetrical components of a voltage or current system (see chapter 4, example 4).

As an illustration, **Figure 10** shows the method for measuring the zero-sequence impedance of an electrical element. The three input terminals are joined together, as are the three output terminals, the whole system is supplied with a phase to neutral voltage E and a current I_o flows in each phase; the zero-sequence impedance is then defined by $Z_o = V / I_o$.

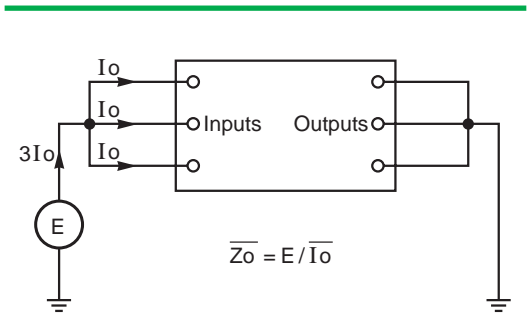

Fig. 10 : Principle of measuring the zero-sequence input impedance of an electrical element.

Notes

- In the remainder of the text, voltage and current vectors are shown without arrows, for the sake of simplicity.
- The symmetrical components of voltages and currents chosen to represent the system in simple terms are those of phase 1:
 $V_i = V_d + V_i + V_o$
- The residual vector $G_{\text{residual}} = 3 \times G_o$ corresponds to any zero-sequence vector G_o .

3 Basic applications

3.1 Method of calculating unbalanced states

Superposition principle

Let us examine the behavior of a linear, symmetrical three-phase network, in other words one that is composed of constant, identical impedances for the three phases (as is the case in practice), comprising only balanced electromotive forces but in which the currents and voltages may be unbalanced due to connection to an asymmetrical zone D.

Electromotive forces (emf) are inherently positive-sequence systems, since the e.m.f. of negative-sequence and zero-sequence systems are zero.

The operation of the network is interpreted by considering the **superposition** of three states, corresponding to the positive-sequence, negative-sequence and zero-sequence systems respectively.

In this linear, symmetrical network, the currents in each system are linked solely to the voltages in the same system and in the same way, by means of the impedances of the system in question. Note that these impedances Z_d , Z_i and Z_o depend on actual impedances, in particular mutual inductances.

For a network comprising a single e.m.f., the symmetrical components of voltage and current being respectively V_d , V_i , V_o , I_d , I_i , I_o , at point D of the asymmetry, the relations defining the three states are:

$$E = V_d + Z_d \times I_d$$

$$0 = V_i + Z_i \times I_i$$

$$0 = V_o + Z_o \times I_o.$$

They are shown in simplified form in **Figure 11**.

These equations remain valid for networks comprising multiple sources, provided that E and Z_d , Z_i , Z_o are considered respectively as the e.m.f. and as the internal impedances of the Thevenin-equivalent generator.

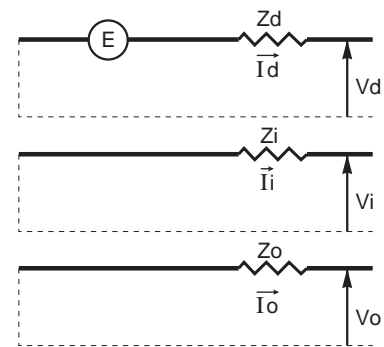

Fig. 11

Practical solution method

The method summarized below is described in detail in the next section (phase-to-ground fault).

- The network is divided into two zones:
 - An asymmetrical zone D (unbalanced network)
 - A symmetrical zone S (balanced network).

■ We write the equations linking currents and voltages:

- In zone D (actual components)
- In zone S (symmetrical components)
- Continuity at the D-S boundary
- Operation in zone S.

■ By solving the equations mathematically, we can calculate the values of the symmetrical components and the actual components of the currents and voltages in zones D and S.

Note that we can calculate the values of the symmetrical components directly using representative diagrams of the symmetrical systems (see Fig. 11).

3.2 Phase-to-ground fault (zero-sequence fault)

The circuit is assumed to be a no-load circuit.

Writing the equations

- Isolation of the asymmetrical zone (see Fig. 12)
- Equations for the actual components in (D)

$$\begin{cases} I_2 = I_3 = 0 \\ V_1 = Z \times I_1 \end{cases}$$

These equations describe the case in question. They are the only ones which are specific to this example.

- Equations for the symmetrical components in (S)

$$\begin{cases} I_1 = I_d + I_i + I_o \\ I_2 = a^2 I_d + a I_i + I_o \\ I_3 = a I_d + a^2 I_i + I_o \\ V_1 = V_d + V_i + V_o \\ V_2 = a^2 V_d + a V_i + V_o \\ V_3 = a V_d + a^2 V_i + V_o \end{cases}$$

These equations link the actual currents and the actual voltages respectively to their symmetrical components. They are the same in all calculations for unbalanced states. They are derived from the definitions set out earlier (see chapter 2).

- Continuity at the D-S boundary
By combining the equations for the actual components in (D) and the equations for the symmetrical components in (S) we obtain:

$$\begin{cases} a^2 I_d + a I_i + I_o = 0 \\ a I_d + a^2 I_i + I_o = 0 \\ V_d + V_i + V_o = Z \times I_1 \end{cases}$$

$$\Rightarrow \begin{cases} I_d = I_i = I_o = \frac{I_1}{3} \\ V_d + V_i + V_o = 3Z \times I_o \end{cases}$$

- Equations for operation in S

$$\begin{cases} E = V_d + Z_d \times I_d \\ 0 = V_i + Z_i \times I_i \\ 0 = V_o + Z_o \times I_o \end{cases}$$

These three equations are found in all calculations for unbalanced states comprising just one voltage source.

Solving the equations

- Values of the symmetrical components of the currents and voltages
- $$E + 0 + 0 = V_d + V_i + V_o + Z_d \times I_d + Z_i \times I_i + Z_o \times I_o$$
- $$= 3Z \times I_o + (Z_d + Z_i + Z_o) I_o$$
- ie.

$$I_o = I_d = I_i = \frac{E}{Z_d + Z_i + Z_o + 3Z}$$

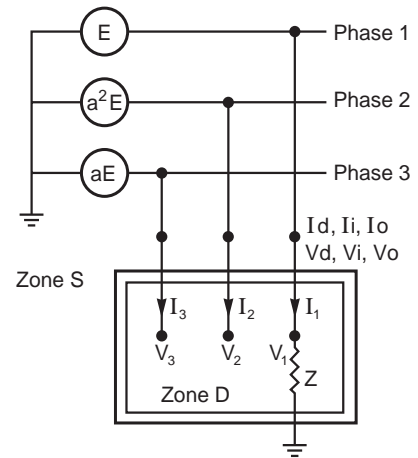

Fig. 12

$$V_d = E - Z_d \times I_d = E - Z_d \frac{E}{Z_d + Z_i + Z_o + 3Z}$$

$$V_d = E \frac{Z_i + Z_o + 3Z}{Z_d + Z_i + Z_o + 3Z}$$

$$V_i = -Z_i \times I_i$$

$$V_i = -Z_i \frac{E}{Z_d + Z_i + Z_o + 3Z}$$

$$V_o = -Z_o \times I_o$$

$$V_o = -Z_o \frac{E}{Z_d + Z_i + Z_o + 3Z}$$

- Network diagram based on symmetrical components (see Fig. 13)

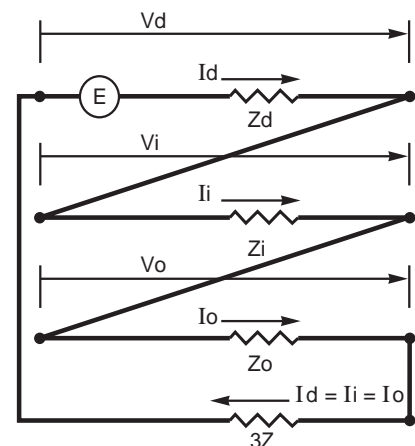

Fig. 13

■ Values of the actual voltages and currents

$$I_1 = I_d + I_i + I_o$$

$$I_1 = \frac{3E}{Z_d + Z_i + Z_o + 3Z}$$

$$I_2 = 0$$

$$I_3 = 0$$

$$V_1 = Z \times I_1$$

$$V_1 = 3Z \frac{E}{Z_d + Z_i + Z_o + 3Z}$$

$$V_2 = a^2 V_d + a V_i + V_o$$

$$= E \frac{Z_i (a^2 - a) + Z_o (a^2 - 1) + 3a^2 Z}{Z_d + Z_i + Z_o + 3Z}$$

$$V_2 = a^2 E \left(1 - \frac{Z_d + a^2 Z_i + a Z_o}{Z_d + Z_i + Z_o + 3Z} \right) = a^2 E k_1$$

$$\text{where } k_1 = 1 - \frac{Z_d + a^2 Z_i + a Z_o}{Z_d + Z_i + Z_o + 3Z}$$

$$V_3 = a V_d + a^2 V_i + V_o$$

$$= E \frac{Z_i (a - a^2) + Z_o (a - 1) + 3a Z}{Z_d + Z_i + Z_o + 3Z}$$

$$V_3 = a E \left(1 - \frac{Z_d + a Z_i + a^2 Z_o}{Z_d + Z_i + Z_o + 3Z} \right) = a^2 E k_2$$

$$\text{where } k_2 = 1 - \frac{Z_d + a Z_i + a^2 Z_o}{Z_d + Z_i + Z_o + 3Z}$$

Special cases

■ Bolted fault

If $Z = 0$, the phase-to-ground fault current takes

$$\text{the value: } I_1 = \frac{3E}{Z_d + Z_i + Z_o}$$

■ Impedance ground fault

If $3Z \gg Z_d + Z_i + Z_o$, the phase-to-ground fault

current is defined by the fault impedance: $I_1 = \frac{E}{Z}$

NB:

The terms k_1 and k_2 are known as ground fault factors; their values vary between 1 and 1.8.

The ground fault factor at a given point is the ratio of the highest rms voltage between a healthy phase and ground when the network is affected by a fault, relative to the rms voltage between phase and ground in the absence of the fault.

Figure 14 shows the overall situation in the special case where $Z = 0$ (bolted fault) and $Z_d = Z_i \approx X_d$.

The range of high values for X_o/X_d corresponds to isolated or compensated neutral networks.

The range of low positive values for X_o/X_d corresponds to neutral-to-ground networks.

The range of low negative values for X_o/X_d is unsuitable in practice due to the existence of resonances.

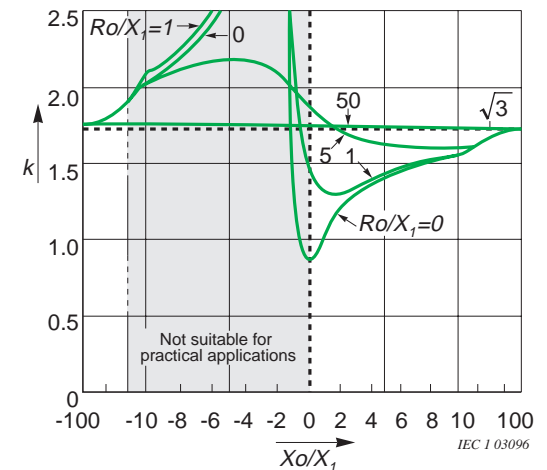

Fig. 14: Ground fault factor as a function of X_o/X_1 for $R_1/X_1 = 0$ and $R = 0$ (graph according to IEC 60071-2).

3.3 Two-phase to ground fault (see Fig. 15 overleaf)

Writing the equations

■ In zone (D)

$$\begin{cases} I_1 = 0 \\ V_2 = V_3 = Z (I_2 + I_3) \end{cases}$$

■ In zone (S)

$$\begin{cases} I_1 = I_d + I_i + I_o \\ I_2 = a^2 I_d + a I_i + I_o \\ I_3 = a I_d + a^2 I_i + I_o \\ V_1 = V_d + V_i + V_o \\ V_2 = a^2 V_d + a V_i + V_o \\ V_3 = a V_d + a^2 V_i + V_o \end{cases}$$

■ Continuity at the (D) - (S) boundary

$$\begin{cases} I_d + I_i + I_o = 0 \\ V_d = V_i \\ V_o = V_d + 3Z \times I_o \end{cases}$$

■ Operation in (S)

$$\begin{cases} E = V_d + Z_d \times I_d \\ 0 = V_i + Z_i \times I_i \\ 0 = V_o + Z_o \times I_o \end{cases}$$

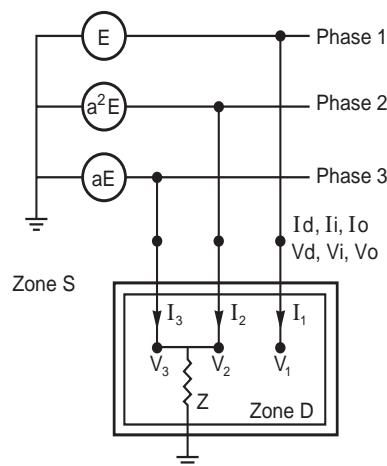

Fig. 15

Solving the equations

$$I_d = E \frac{Z_i + Z_o + 3Z}{Z_d \times Z_i + (Z_o + 3Z)(Z_d + Z_i)}$$

$$I_i = \frac{-E (Z_o + 3Z)}{Z_d \times Z_i + (Z_d + Z_i)(Z_o + 3Z)}$$

$$I_o = \frac{-E \times Z_i}{Z_d \times Z_i + (Z_d + Z_i)(Z_o + 3Z)}$$

$$V_d = V_i = \frac{E \times Z_i (Z_o + 3Z)}{Z_d \times Z_i + (Z_d + Z_i)(Z_o + 3Z)}$$

$$V_o = \frac{E \times Z_i \times Z_o}{Z_d \times Z_i + (Z_d + Z_i)(Z_o + 3Z)}$$

$$I_1 = 0$$

$$I_2 = -j\sqrt{3} E \frac{Z_o + 3Z - aZ_i}{Z_d \times Z_i + (Z_d + Z_i)(Z_o + 3Z)}$$

$$I_3 = j\sqrt{3} E \frac{Z_o + 3Z - a^2Z_i}{Z_d \times Z_i + (Z_d + Z_i)(Z_o + 3Z)}$$

$$I_2 + I_3 = -3E \frac{Z_i}{Z_d \times Z_i + (Z_d + Z_i)(Z_o + 3Z)}$$

$$V_1 = E \frac{3Z_i (Z_o + 2Z)}{Z_d \times Z_i + (Z_d + Z_i)(Z_o + 3Z)}$$

$$V_2 = V_3 = E \frac{-3Z \times Z_i}{Z_d \times Z_i + (Z_d + Z_i)(Z_o + 3Z)}$$

■ Network diagram based on symmetrical components (see Fig. 16)

Special cases

■ Bolted fault

If $Z = 0$, the phase-to-ground fault current assumes the value:

$$I_2 + I_3 = -\frac{3E \times Z_i}{Z_d \times Z_i + Z_i \times Z_o + Z_d \times Z_o}$$

■ Two-phase fault

If $Z = \infty$, the phase fault current is then:

$$I_2 = -I_3 = E \frac{(a^2 - a)}{Z_d + Z_i} = -jE \frac{\sqrt{3}}{Z_d + Z_i}$$

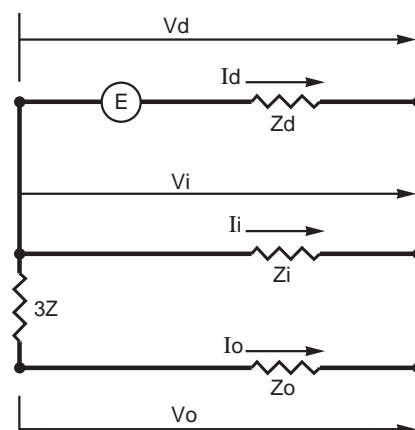

Fig. 16

3.4 Three-phase fault (see Fig. 17 overleaf)

Writing the equations

■ In zone (D)

$$V_1 = V_2 = V_3 = Z (I_1 + I_2 + I_3)$$

■ In zone (S)

$$\begin{cases} I_1 = I_d + I_i + I_o \\ I_2 = a^2 I_d + a I_i + I_o \\ I_3 = a I_d + a^2 I_i + I_o \\ V_1 = V_d + V_i + V_o \\ V_2 = a^2 V_d + a V_i + V_o \\ V_3 = a V_d + a^2 V_i + V_o \end{cases}$$

■ Continuity at the (D) - (S) boundary

$$\begin{cases} I_1 + I_2 + I_3 = 3I_o = \frac{V_o}{Z} \\ V_d = V_i = 0 \\ V_1 = V_2 = V_3 = V_o \end{cases}$$

■ Operation in (S)

$$\begin{cases} E = V_d + Z_d \times I_d \\ 0 = V_i + Z_i \times I_i \\ 0 = V_o + Z_o \times I_o \end{cases}$$

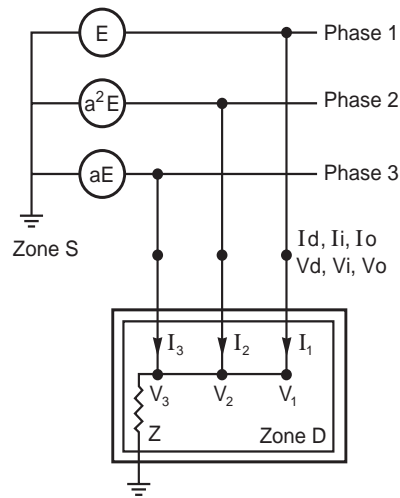

Fig. 17

Solving the equations

$$I_d = \frac{E}{Z_d} \quad \text{and} \quad I_i = I_o = 0$$

$$V_d = V_i = V_o = 0$$

$$I_1 = \frac{E}{Z_d}$$

$$I_2 = a^2 \frac{E}{Z_d}$$

$$I_3 = a \frac{E}{Z_d}$$

$$V_1 = V_2 = V_3 = 0$$

The results are independent of the values Z, Zi and Zo.

■ Network diagram based on symmetrical components (see Fig. 18).

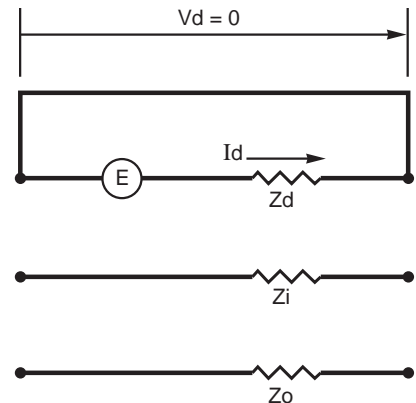

Fig. 18

3.5 Network with an unbalanced load (see Fig. 19)

Writing the equations

■ In zone (D)

$$\begin{cases} I_1 = 0 \\ V_3 - V_2 = I_3 Z_c = -I_2 Z_c \end{cases}$$

■ In zone (S)

$$\begin{cases} I_1 = I_d + I_i + I_o \\ I_2 = a^2 I_d + a I_i + I_o \\ I_3 = a I_d + a^2 I_i + I_o \\ V_1 = V_d + V_i + V_o \\ V_2 = a^2 V_d + a V_i + V_o \\ V_3 = a V_d + a^2 V_i + V_o \end{cases}$$

■ Continuity at the (D) - (S) boundary

$$\begin{cases} I_o = 0 \\ I_d = -I_i \\ V_d - V_i = Z_c \times I_d \end{cases}$$

■ Operation in (S)

$$\begin{cases} E = V_d + Z_d \times I_d \\ 0 = V_i + Z_i \times I_i \\ 0 = V_o + Z_o \times I_o \end{cases}$$

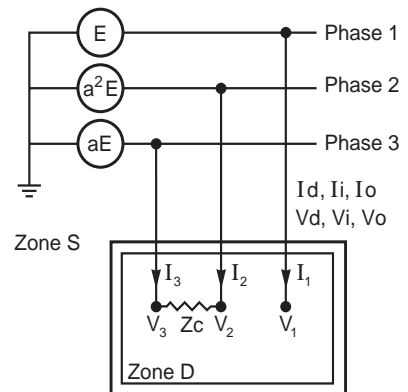

Fig. 19

Solving the equations

$$I_d = \frac{E}{Z_d + Z_i + Z_c}$$

$$I_i = -\frac{E}{Z_d + Z_i + Z_c}$$

$$I_o = 0$$

$$V_d = \frac{E(Z_i + Z_c)}{Z_d + Z_i + Z_c}$$

$$V_i = \frac{E \times Z_i}{Z_d + Z_i + Z_c}$$

$$V_o = 0$$

$$I_1 = 0$$

$$I_2 = -j \frac{E\sqrt{3}}{Z_d + Z_i + Z_c}$$

$$I_3 = j \frac{E\sqrt{3}}{Z_d + Z_i + Z_c}$$

$$V_1 = \frac{E(2Z_i + Z_c)}{Z_d + Z_i + Z_c}$$

$$V_2 = \frac{E(a^2 Z_c - Z_i)}{Z_d + Z_i + Z_c}$$

$$V_3 = \frac{E(a Z_c - Z_i)}{Z_d + Z_i + Z_c}$$

■ Network diagram based on symmetrical components (see Fig. 20).

Special cases

■ Low-power load

If $Z_c \rightarrow \infty$ then I_1 and $I_3 \rightarrow 0$

and V_1, V_2, V_3 tend towards the values of the symmetrical network, in other words towards E, a^2E, aE .

■ Two-phase short-circuit clear of ground

If $Z_c = 0$ the fault current is then equal to

$$I_3 = -I_3 = j \frac{E\sqrt{3}}{Z_d + Z_i}$$

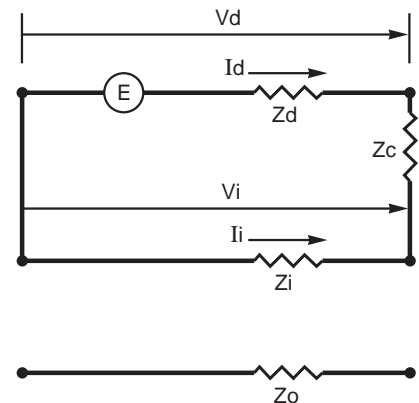

Fig. 20

3.6 Network with one open phase (see Fig. 21)

Writing the equations

■ In zone (D)

$$\begin{cases} I_1 = 0 \\ V_2 = V'_2 \\ V_3 = V'_3 \end{cases}$$

■ In zone (S)

$$\begin{cases} I_1 = I_d + I_i + I_o \\ I_2 = a^2 I_d + a I_i + I_o \\ I_3 = a I_d + a^2 I_i + I_o \\ V_1 = V_d + V_i + V_o \\ V_2 = a^2 V_d + a V_i + V_o \\ V_3 = a V_d + a^2 V_i + V_o \\ V'_1 = V'_d + V'_i + V'_o \\ V'_2 = a^2 V'_d + a V'_i + V'_o \\ V'_3 = a V'_d + a^2 V'_i + V'_o \end{cases}$$

■ Continuity at the (D) - (S) boundary

$$\begin{cases} I_d + I_i + I_o = 0 \\ V_d - V'_d = V_i - V'_i \end{cases}$$

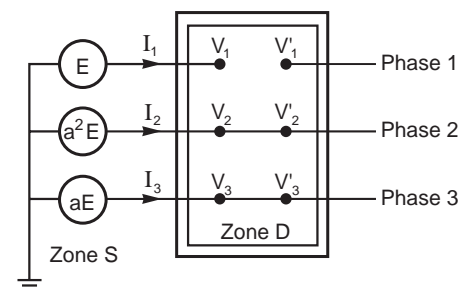

Fig. 21

■ Operation in (S)

$$\begin{cases} E = V_d + z_d \times I_d \\ 0 = V_i + z_i \times I_i \\ 0 = V_o + z_o \times I_o \\ 0 = V'_d - z'_d \times I_d \\ 0 = V'_i - z'_i \times I_i \\ 0 = V'_o - z'_o \times I_o \\ Z_d = z_d + z'_d \\ Z_i = z_i + z'_i \\ Z_o = z_o + z'_o \end{cases}$$

Solving the equations

$$I_d = E \frac{Z_i + Z_o}{Z_d \times Z_i + Z_d \times Z_o + Z_i \times Z_o}$$

$$I_i = -E \frac{Z_o}{Z_d \times Z_i + Z_d \times Z_o + Z_i \times Z_o}$$

$$I_o = -E \frac{Z_i}{Z_d \times Z_i + Z_d \times Z_o + Z_i \times Z_o}$$

$$V_d = E \frac{[z'd(Z_i + Z_o) + Z_i \times Z_o]}{Z_d \times Z_i + Z_d \times Z_o + Z_i \times Z_o}$$

and $V'd = E \frac{z'd(Z_i + Z_o)}{Z_d \times Z_i + Z_d \times Z_o + Z_i \times Z_o}$

$$V_i = E \frac{Z_o \times z_i}{Z_d \times Z_i + Z_d \times Z_o + Z_i \times Z_o}$$

and $V'i = -E \frac{Z_o \times z'i}{Z_d \times Z_i + Z_d \times Z_o + Z_i \times Z_o}$

$$V_o = E \frac{Z_i \times z_o}{Z_d \times Z_i + Z_d \times Z_o + Z_i \times Z_o}$$

and $V'o = -E \frac{Z_i \times z'o}{Z_d \times Z_i + Z_d \times Z_o + Z_i \times Z_o}$

$$I_1 = 0$$

$$I_2 = E \frac{Z_i(a^2 - 1) - j\sqrt{3}Z_o}{Z_d \times Z_i + Z_d \times Z_o + Z_i \times Z_o}$$

$$I_3 = E \frac{Z_i(a^2 - 1) + j\sqrt{3}Z_o}{Z_d \times Z_i + Z_d \times Z_o + Z_i \times Z_o}$$

$$V_1 = E \frac{z'd(Z_i + Z_o) + Z_i \times Z_o + z_i \times Z_o + Z_i \times z_o}{Z_d \times Z_i + Z_d \times Z_o + Z_i \times Z_o}$$

and $V'_1 = E \frac{z'd(Z_i + Z_o) - Z_o \times z'i - Z_i \times z'o}{Z_d \times Z_i + Z_d \times Z_o + Z_i \times Z_o}$

ie.

$$V_1 - V'_1 = 3E \frac{Z_i \times Z_o}{Z_d \times Z_i + Z_d \times Z_o + Z_i \times Z_o}$$

$$V_2 = V'_2 = E \frac{a^2[z'd(Z_i + Z_o) + Z_i \times Z_o] + aZ_o \times z_i + Z_i \times z_o}{Z_d \times Z_i + Z_d \times Z_o + Z_i \times Z_o}$$

$$V_3 = V'_3 = E \frac{a[z'd(Z_i + Z_o) + Z_i \times Z_o] + a^2Z_o \times z_i + Z_i \times z_o}{Z_d \times Z_i + Z_d \times Z_o + Z_i \times Z_o}$$

■ Network diagram based on symmetrical components (see Fig. 22).

Special cases

■ If the load is isolated, the zero-sequence impedance of the system is very high. The current in the non-open phases is:

$$I_2 = -I_3 = -jE \frac{\sqrt{3}}{Z_d + Z_i}$$

The voltage in the open phase is:

$$V_1 - V'_1 = 3E \frac{Z_i}{Z_d + Z_i}$$

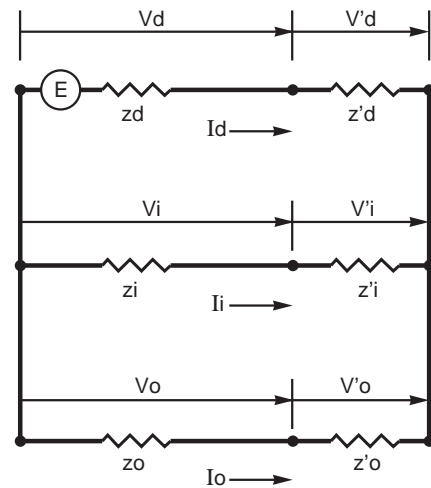

Fig. 22

3.7 Impedances associated with symmetrical components

In this section we consider the main elements which can be involved in an electrical network. For rotating machines and transformers, the orders of magnitude of the impedances are shown as percentages:

$$\left(z \% = 100 Z \frac{S_n}{U_n^2} \right)$$

where:

U_n = rated voltage,
 S_n = rated apparent power,
 Z = cyclic impedance.

Synchronous machines

Generators generate the positive-sequence component of the power. Faults produce the

negative-sequence and zero-sequence components, which move from the location of the fault towards the balanced elements, gradually weakening as they do so.

■ When disturbance occurs, the positive-sequence reactance of a machine varies from its subtransient value to its synchronous value. In a fault calculation, the following percentage values can be used:

Reactance %	Salient poles	Constant air gap
Subtransient	30	20
Transient	40	25
Synchronous	120	200

- The negative-sequence reactance is less than the transient positive-sequence reactance, at around 20%.

- The zero-sequence reactance is only taken into account if the neutral of the alternator is connected to ground directly or via a coil/resistor. Its value is around half that of the subtransient reactance, at around 10%.

Asynchronous machines

In motors the positive-sequence component generates rotating fields in the positive direction (useful torque).

The negative-sequence component produces rotating fields which generate braking torques.

- The positive-sequence reactance can generally be considered as a passive impedance: $U^2 / (P - jQ)$.

- The negative-sequence reactance varies between 15% and 30%.

It is approximately equal to the starting reactance.

- The zero-sequence reactance is very low.

Transformers

The circulation of a zero-sequence current in the windings of a transformer requires a connection whose neutral point is connected to ground or to a neutral conductor.

- In positive-sequence and negative-sequence systems they give currents an impedance equal to their short-circuit impedance of around 4% to 15%.

- The zero-sequence reactance depends on the way in which the windings are connected and on the nature of the magnetic circuit.

The table in **Figure 23** sets out the orders of magnitude of this reactance and shows various possible connections. A table in the Appendix shows the value or the method of calculating X_0 for each connection mode.

Transformer (seen from secondary)	Zero-sequence reactance	
No neutral	∞	
Yyn or Zyn	Free flux	∞
	Forced flux	10 to 15 X_d
Dyn or YNyn	X_d	
Primary zn	0.1 to 0.2 X_d	

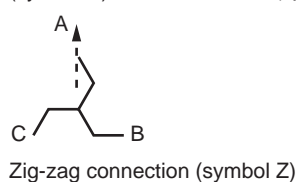
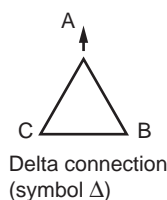
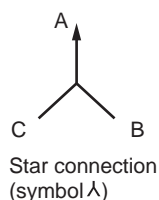

Zigzag connections are only used on the secondary side of distribution transformers.

Fig. 23

A connection is designated by a set of two symbols:

- The first (upper-case) is assigned to the highest voltage.

- The second (lower-case) is assigned to the lowest voltage.

The designation also includes the phase angle value (vector group). For economic reasons and to obtain an adequate tolerance of the load unbalance between phases, the usual connections in HV/LV distribution are as follows:

- Yzn 11 for 50 kVA,

- Dyn 11 from 100 to 3150 kVA. Where:

D : Delta connection in HV

d : Delta connection in LV

Y : Star connection in HV

y : Star connection in LV

Z : Zigzag connection in HV

z : Zigzag connection in LV

N : External neutral in HV

n : External neutral in LV

11: Vector group defining the phase angle between HV and LV.

Overhead lines

Let us consider transposed lines:

- The positive-sequence or negative-sequence impedance and capacity depend on the geometry of the line.
- The zero-sequence impedance is roughly three times the positive-sequence impedance. The zero-sequence capacity is around 0.6 times the positive-sequence capacity.

Line		LV	MV	HV
Rd = Ri	Ω/km	0.3	0.7	0.02 to 0.12
Xd = Xi	Ω/km	0.3	0.4	0.2 to 0.4
Cd = Ci	nF/km		10	9 to 13
	μS/km		3.3	3 to 4
Ro	Ω/km			0.25
Xo	Ω/km		1.8	0.75 to 1.5
Co	nF/km		5	4.5 to 9
	μS/km			1.5 to 3

Cables

- The positive-sequence and negative-sequence reactance and capacity depend on the geometry of the cables.
- The zero-sequence characteristics of a cable cannot easily be deduced from the positive-sequence and negative-sequence characteristics. They are generally negligible in comparison with those of the transformers they are supplying.

Cable		LV	MV	HV
Rd = Ri	Ω/km	0.12 to 0.16	0.08 to 0.16	0.02 to 0.05
Xd = Xi	Ω/km	0.06 to 0.10	0.08 to 0.12	0.1 to 0.2
Cd = Ci	μF/km	1	0.1 to 0.6	0.2
	mS/km	0.3	0.03 to 0.2	0.07
Ro	Ω/km	1	0.1	
Xo	Ω/km	0.12 to 0.2	0.16	
Co	μF/km	2	0.1 to 0.6	0.1 to 0.6
	mS/km	0.6	0.03 to 0.2	0.03 to 0.2

3.8 Summary formulae

Notation

- rms phase-to-phase voltage = U
- rms phase-to-neutral voltage $V = U/\sqrt{3}$
- Short-circuit current in module = I_{sc}
- Ground fault current in module = I_{ground}

- Symmetrical impedances = Z_d, Z_i, Z_o
- Short-circuit impedance = Z_c
- Ground impedance = Z

The table below summarizes the currents in the module in various asymmetries.

Type of asymmetry	Impedance asymmetry	Solid asymmetry (Z = 0 and/or Z _c = 0)
Single-phase short-circuit	$I_{sc} = \frac{U\sqrt{3}}{ Z_d + Z_i + Z_o + 3Z } = \frac{3V}{ Z_d + Z_i + Z_o }$	$I_{sc} = \frac{U\sqrt{3}}{ Z_d + Z_i + Z_o } = \frac{3V}{ Z_d + Z_i + Z_o }$
Two-phase short-circuit to ground (Z _c = 0)	$I_{ground} = \frac{U\sqrt{3} Z_i }{ Z_d \times Z_i (Z_d + Z_i)(Z_o + 3Z) }$	$I_{ground} = \frac{U\sqrt{3} Z_i }{ Z_d \times Z_i + Z_i \times Z_o + Z_d \times Z_o }$
Two-phase short-circuit clear of ground (Z = ∞)	$I_{sc} = \frac{U}{ Z_d + Z_i + Z_c } = \frac{V\sqrt{3}}{ Z_d + Z_i + Z_o }$	$I_{sc} = \frac{U}{ Z_d + Z_i } = \frac{V\sqrt{3}}{ Z_d + Z_i }$
Three-phase short-circuit (any Z)	$I_{sc} = \frac{U}{ Z_d + Z_c \sqrt{3}} = \frac{V}{ Z_d + Z_c }$	$I_{sc} = \frac{U}{ Z_d \sqrt{3}} = \frac{V}{ Z_d }$

4 Worked examples

4.1 Breaking capacity of a circuit-breaker at the supply end (see Fig. 24)

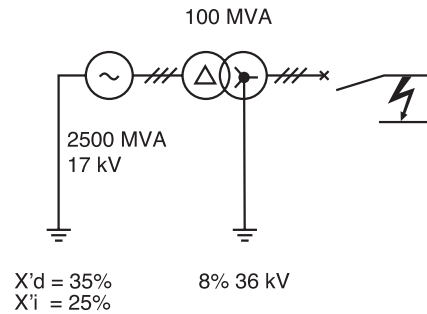

Fig. 24

Problem

What should be the breaking power of the circuit-breaker?

Solution

When the circuit-breaker is tripped, the aperiodic component is switched off inside the network but not inside the windings of the alternator.

■ Impedances

□ of the alternator reduced to the secondary transformer:

$$\text{Positive - sequence } Z_a = \frac{35}{100} \times \frac{36^2}{2500} = j0.18 \Omega$$

$$\text{Negative - sequence } Z_a = \frac{25}{100} \times \frac{36^2}{2500} = j0.13 \Omega$$

Zero-sequence $Z_a =$ disregarded

□ of the transformer reduced to the secondary transformer:

$$\text{Positive - sequence } Z_t = \frac{8}{100} \times \frac{36^2}{100} = j1.04 \Omega$$

Negative-sequence $Z_t = j1.04 \Omega$

Zero-sequence $Z_t = j1.04 \Omega$

□ Total impedances:

Positive-sequence $Z = j1.22 \Omega$

Negative-sequence $Z = j1.17 \Omega$

Zero-sequence $Z_t = j1.04 \Omega$

■ Short-circuit currents

□ Three-phase

$$I_{sc} = \frac{U}{\sqrt{3} |Z_d|} = \frac{36}{\sqrt{3} \times 1.22} = 17 \text{ kA}$$

□ Single-phase

$$I_{sc} = \frac{U\sqrt{3}}{|Z_d + Z_i + Z_o|}$$

$$= \frac{36\sqrt{3}}{1.22 + 1.17 + 1.0} = 18 \text{ kA}$$

□ Two-phase clear of ground

$$I_{sc} = \frac{U}{|Z_d + Z_i|} = \frac{36}{1.22 + 1.17} = 15 \text{ kA}$$

□ Two-phase-to-ground

$$I_{sc} = \frac{U |Z_o - a Z_i|}{|Z_d \times Z_i + Z_i \times Z_o + Z_o \times Z_d|}$$

$$= \frac{36 \times 1.915}{3.91} = 17.6 \text{ kA}$$

■ The circuit-breaker must therefore break a short-circuit current of 18 kA, giving a breaking capacity of:

$$18 \times 36 \sqrt{3} = 1122 \text{ MVA}$$

4.2 Breaking capacity of circuit-breakers at the ends of a line (see Fig. 25)

Problem

In a 60 kV network, determine the breaking capacity of the circuit-breakers at substations C and E supplying the 15 km line.

The short-circuit reactance of the power station unit and network transformers is 10% and that of the other transformers is 8%.

For a 60 kV line, the reactance is:

- 0.40 Ω/km in a positive-sequence or negative-sequence state,

- $3 \times 0.40 \text{ } \Omega/\text{km}$ in a zero-sequence state.

The power station units have a positive-sequence or negative-sequence reactance of 25%.

The active power loads P have an estimated equivalent reactance of $j \times 0.6U^2/P$.

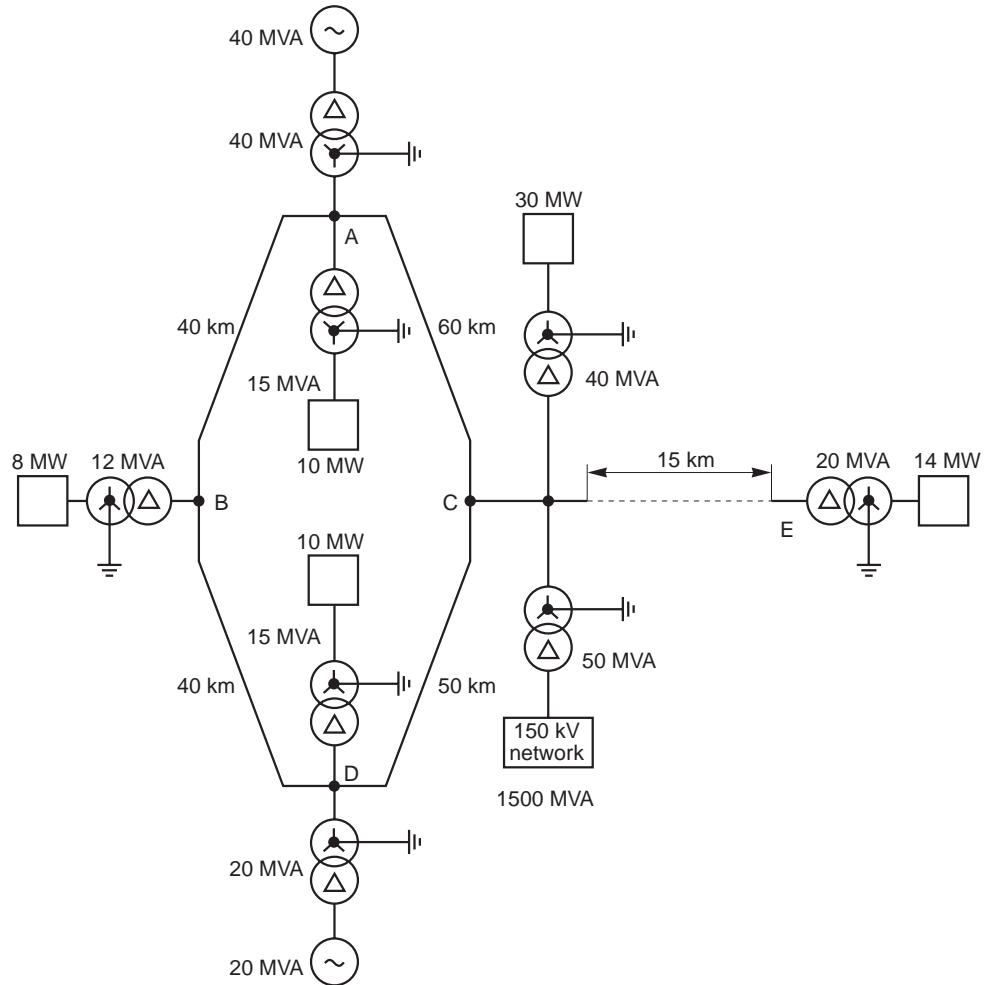

Fig. 25

Solution

■ Global positive-sequence or negative-sequence diagram (reduction to 60 kV) (see Fig. 26)

$$a = j \frac{U^2}{P_{sc}} \times \frac{25}{100} = \frac{60^2}{40} \times \frac{25}{100} = j22.5 \Omega$$

$$b = jU_{sc} \frac{U^2}{P_{sc}} \times \frac{10}{100} = \frac{60^2}{400} = j9 \Omega$$

$$C_1 = j0.40 \times 60 = j24 \Omega$$

$$C_2 = j0.40 \times 50 = j20 \Omega$$

$$C_3 = j0.40 \times 40 = j16 \Omega$$

$$C_4 = j0.40 \times 40 = j16 \Omega$$

$$d = jU_{sc} \frac{U^2}{P_{sc}} \times \frac{8}{100} = \frac{60^2}{15} = j19.2 \Omega$$

$$e = j \frac{U^2}{P} \times 0.6 = \frac{60^2}{10} \times 0.6 = j216 \Omega$$

$$f = jU_{sc} \frac{U^2}{P_{sc}} = \frac{8}{100} \times \frac{60^2}{12} = j24 \Omega$$

$$g = j \frac{U^2}{P} \times 0.6 = \frac{60^2}{8} \times 0.6 = j270 \Omega$$

$$h = jU_{sc} \frac{U^2}{P_{sc}} = \frac{8}{100} \times \frac{60^2}{15} = j19.2 \Omega$$

$$i = j \frac{U^2}{P} \times 0.6 = \frac{60^2}{10} \times 0.6 = j216 \Omega$$

$$j = jU_{sc} \frac{U^2}{P_{sc}} = \frac{10}{100} \times \frac{60^2}{20} = j18 \Omega$$

$$k = j \frac{U^2}{P_{sc}} \times \frac{25}{100} = \frac{60^2}{20} \times \frac{25}{100} = j45 \Omega$$

$$l = jU_{sc} \frac{U^2}{P_{sc}} = \frac{8}{100} \times \frac{60^2}{40} = j7.2 \Omega$$

$$m = j \frac{U^2}{P} \times 0.6 = \frac{60^2}{30} \times 0.6 = j72 \Omega$$

$$n = jU_{sc} \frac{U^2}{P_{sc}} = \frac{10}{100} \times \frac{60^2}{50} = j7.2 \Omega$$

$$o = j \frac{U^2}{P_{sc}} = \frac{60^2}{1500} = j2.4 \Omega$$

$$p = j0.4 \times 15 = j2.4 \Omega$$

$$q = jU_{sc} \frac{U^2}{P_{sc}} = \frac{8}{100} \times \frac{60^2}{20} = j14.4 \Omega$$

$$r = j \frac{U^2}{P} \times 0.6 = \frac{60^2}{14} \times 0.6 = j154 \Omega$$

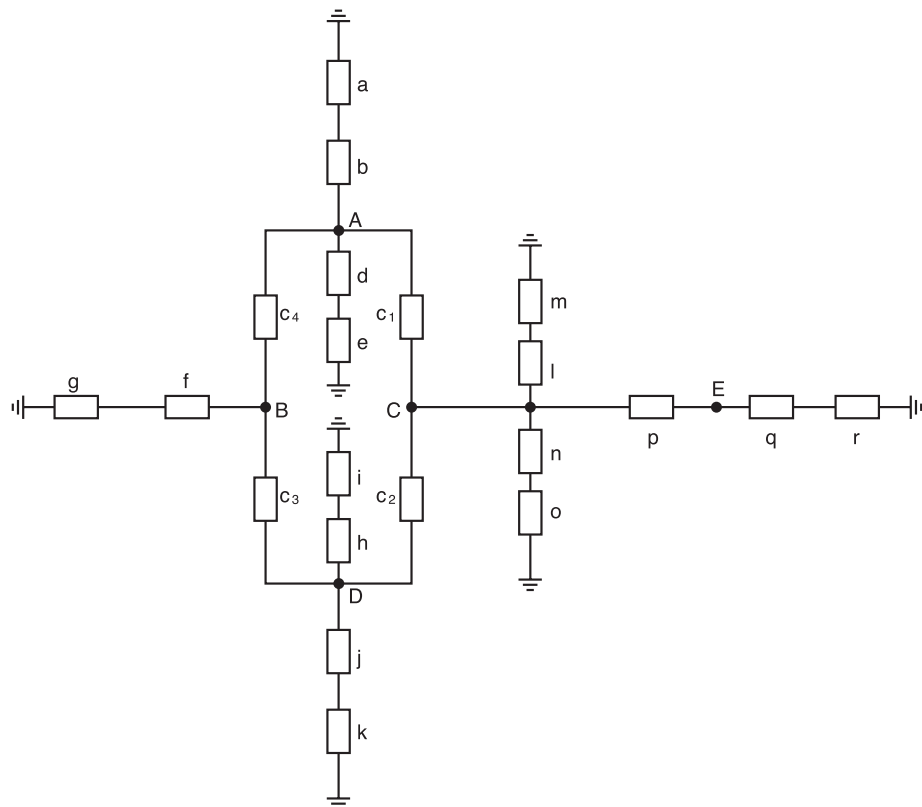

Fig. 26

■ Global zero-sequence diagram (reduction to 60 kV) (see Fig. 27)

The substation transformers stop zero-sequence currents in the delta windings.

- $b' = b = j9 \Omega$
- $c'_1 = 3c_1 = j72 \Omega$
- $c'_2 = 3c_2 = j60 \Omega$
- $c'_3 = 3c_3 = j48 \Omega$
- $c'_4 = 3c_4 = j48 \Omega$
- $d' = \infty$
- $f' = \infty$
- $h' = \infty$
- $j' = j = j18 \Omega$
- $l' = \infty$
- $n' = n = j7,2 \Omega$
- $p' = 3p = j18 \Omega$
- $q' = \infty$

■ Reduced diagrams

For the study with which we are concerned, we can reduce the diagrams to focus on C and E only (see Fig. 28).

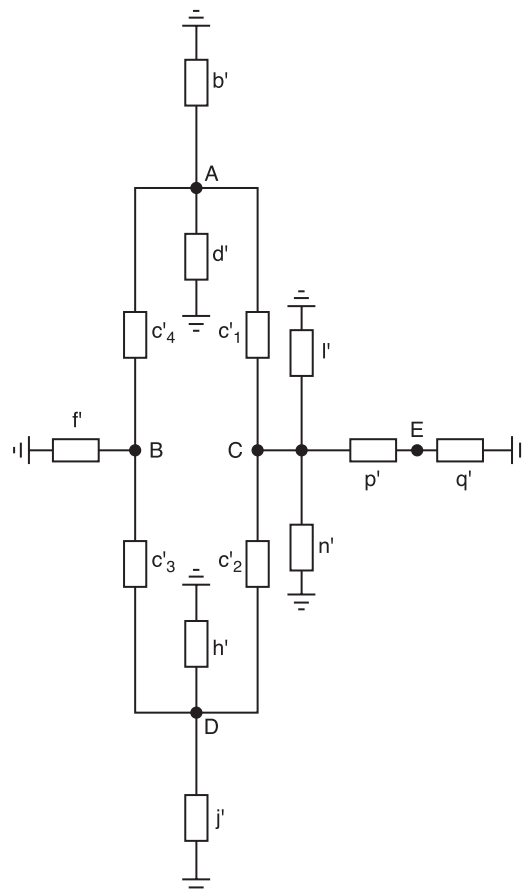

Fig. 27

■ Dimensioning of the line circuit-breaker at C
Case 1: Busbar fault (see Fig. 29)

$$Z_d = j6 + j168.4 = j174.4 \Omega$$

$$Z_o = \infty$$

□ Three-phase I_{sc} is equal to:

$$\frac{U}{|Z_d| \sqrt{3}} = \frac{60}{174.4 \sqrt{3}} = 0.195 \text{ kA}$$

$$\text{so } P_{sc} = UI \sqrt{3} = 20.7 \text{ MVA}$$

□ Single-phase I_{sc} is equal to:

$$\frac{U \sqrt{3}}{|Z_d + Z_i + Z_o|} = 0$$

$$\text{so } P_{sc} = 0$$

Case 2: Line fault (see Fig. 30 overleaf)

$$Z_d = j6.45 \Omega$$

$$Z_o = j6.09 \Omega$$

□ Three-phase I_{sc} is equal to:

$$\frac{U}{|Z_d| \sqrt{3}} = \frac{60}{6.45 \sqrt{3}} = 5.37 \text{ kA}$$

$$\text{so } P_{sc} = UI \sqrt{3} = 558.1 \text{ MVA}$$

Positive-sequence/negative-sequence diagram

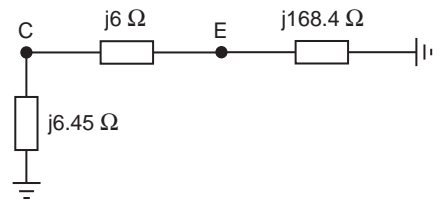

Zero-sequence diagram

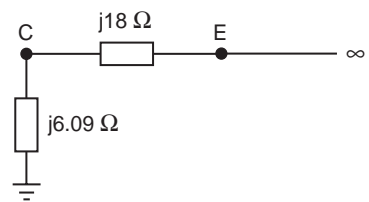

Fig. 28

Positive-sequence diagram



Zero-sequence diagram



Fig. 29

Positive-sequence diagram

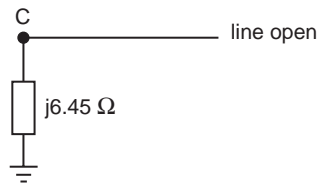

Zero-sequence diagram

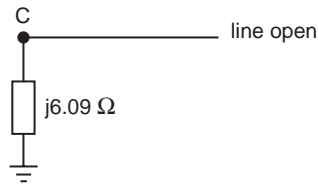

Fig. 30

□ Single-phase I_{sc} is equal to:

$$\frac{U \sqrt{3}}{|Z_d + Z_i + Z_o|} = \frac{60 \sqrt{3}}{18.99} = 5.47 \text{ kA}$$

so $P_{sc} = UI \sqrt{3} = 568.7 \text{ MVA}$

The line circuit-breaker at point C must therefore be dimensioned to 570 MVA.

■ Dimensioning of the line circuit-breaker at E

Case 1: Busbar fault (see Fig. 31)

$$Z_d = j 6 + j 6.45 = j12.45 \Omega$$

$$Z_o = j 18 + j 6.09 = j 24.09 \Omega$$

□ Three-phase I_{sc} is equal to:

$$\frac{U}{|Z_d| \sqrt{3}} = \frac{60}{12.45 \sqrt{3}} = 2.782 \text{ kA}$$

so $P_{sc} = UI \sqrt{3} = 289.2 \text{ MVA}$

□ Single-phase I_{sc} is equal to:

$$\frac{U \sqrt{3}}{|Z_d + Z_i + Z_o|} = \frac{60 \sqrt{3}}{48.99} = 2.121 \text{ kA}$$

so $P_{sc} = UI \sqrt{3} = 220.5 \text{ MVA}$

Case 2: Line fault (see Fig. 32)

$$Z_d = j168.4 \Omega$$

$$Z_o = \infty$$

Positive-sequence diagram

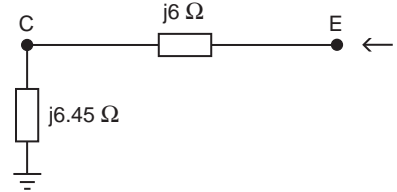

Zero-sequence diagram

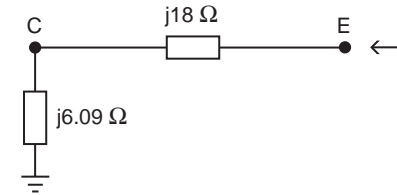
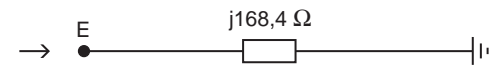

Fig. 31

Positive-sequence diagram



Zero-sequence diagram



Fig. 32

□ Three-phase I_{sc} is equal to:

$$\frac{U}{|Z_d| \sqrt{3}} = \frac{60}{168.4 \sqrt{3}} = 0.206 \text{ kA}$$

so $P_{sc} = UI \sqrt{3} = 21.4 \text{ MVA}$

□ Single-phase I_{sc} is equal to:

$$\frac{U \sqrt{3}}{|Z_d + Z_i + Z_o|} = 0$$

so $P_{sc} = 0$

The line circuit-breaker at point E must therefore be dimensioned to 290 MVA.

4.3 Settings for zero-sequence protection devices in a grounded neutral MV network

(see Fig. 33 overleaf)

Problem

What should the intensity setting be for the zero-sequence relays on the various feeders?

Solution

We start from the formulae in the section on phase-to-ground faults; in addition, we note that the ground impedance R_n is equivalent to three

impedances of value $3R_n$, each placed on one phase of the network connected directly to ground. The zero-sequence current at the point of the ground fault splits into two parallel channels:

■ The first corresponds to the neutral impedance $3R_n$ in series with the zero-sequence impedance

of the transformer and of the section of conductor between the fault and the transformer.
ie. $3R_n + Z_{OT} + Z_{OL}$.

■ The second corresponds to the parallel connection of the conductor capacitive circuits:

$$\frac{-j}{\left(\sum_1^n C_{oi}\right) \omega}$$

Strictly speaking, we should take the transformer and line impedances into account. They are, however, negligible in comparison with the capacitive impedances.

Ground fault current I_1 (see § 3.2):

$$I_1 = \frac{3E}{Z_d + Z_i + Z_o + 3Z}$$

where:

$$Z_o = (3R_n + Z_{OT} + Z_{OL})$$

in parallel with

$$\frac{-j}{\left(\sum_1^n C_{oi}\right) \omega}$$

so

$$Z_o = \frac{3R_n + Z_{OT} + Z_{OL}}{1 + j(3R_n + Z_{OT} + Z_{OL}) \left(\sum_1^n C_{oi}\right) \omega}$$

By substitution:

$$I_1 = \frac{3E \left[1 + j(3R_n + Z_{OT} + Z_{OL}) \left(\sum_1^n C_{oi}\right) \omega \right]}{(Z_d + Z_i + 3Z) \left[1 + j(3R_n + Z_{OT} + Z_{OL}) \left(\sum_1^n C_{oi}\right) \omega \right] + 3(3R_n + Z_{OT} + Z_{OL})}$$

If, as is often the case, Z_d , Z_i , Z_{OT} , Z_{OL} are negligible in comparison with $3R_n$ and the fault is bolted ($Z = 0$) then:

$$I_1 \approx \frac{E}{R_n} + j3 \left(\sum_1^n C_{oi}\right) \omega E$$

The contribution of each healthy feeder to the ground current is therefore $3 C_{oi} \omega E$ (in module). The setting for the zero-sequence relay for each of these feeders must therefore be greater than this capacitive current, to prevent unintentional tripping. This current depends on the type and length of the conductors.

For example:

□ For a 15 kV line the zero-sequence capacity is around 5 nF/km, giving a current of:
 $3 \times 5 \times 10^{-9} \cdot 314 \times 15000/\sqrt{3} = 0.04$ A/km or 4 A per 100 km.

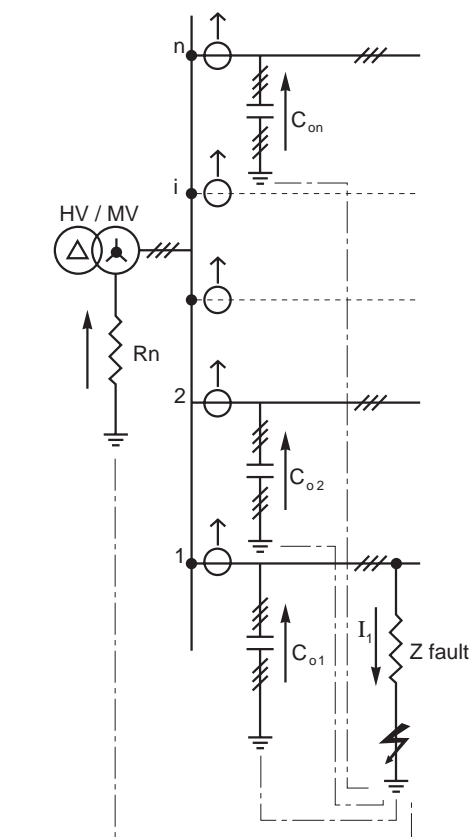

Fig. 33

□ For a 15 kV three-core cable the zero-sequence capacity is around 200 nF/km, giving a current of:

$$3 \times 200 \cdot 10^{-9} \times 314 \times 15000/\sqrt{3} = 1.63$$
 A/km or almost 2 A per km.

□ It is worth comparing these capacitive current values with those for the current crossing the neutral impedance, which currently amount to several tens to several hundreds of amps.

Numerical application and graphical representation (see Fig. 34 overleaf)

Consider a bolted fault on a 5500 V - 50 Hz impedant neutral power system, where:

$$R_n = 100 \Omega$$

$$C_o = 1 \mu F$$

$$Z = Z_d = Z_i = Z_{OT} = Z_{OL} = 0$$

$$E = \frac{5500}{\sqrt{3}} = 3175 \text{ V}$$

$$Z_0 = \frac{3R_n}{1 + j3R_n C_0 \omega}$$

$$I_1 = \frac{3175}{100} + j3 \times 3175 \times 10^{-6} \times 314$$

$$\approx (32 + j3) \text{ amps}$$

$$I_2 = I_3 = 0$$

$$V_1 = 0$$

$$V_2 = ja E \sqrt{3} = -3175 \left(1.5 + j \frac{\sqrt{3}}{2} \right) \text{ volts}$$

$$V_3 = E (a - 1) = -3175 \left(-1.5 + j \frac{\sqrt{3}}{2} \right) \text{ volts}$$

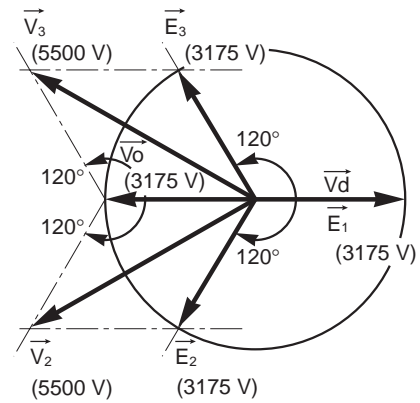

Fig. 34

4.4 Settings for a protection device with a negative-sequence current in an electrical installation

Problem

What should be the setting for the protection device with a negative-sequence current (ANSI 46) on an electrical switchboard supplying Passive Loads and Motors (see Fig. 35) when a phase is opened?

Solution

Let us start from the simplified formulae in section 3.6 (Network with one open phase), with ungrounded loads and hence a high zero-sequence impedance.

In addition, the network impedances are disregarded because they are lower than the load impedances.

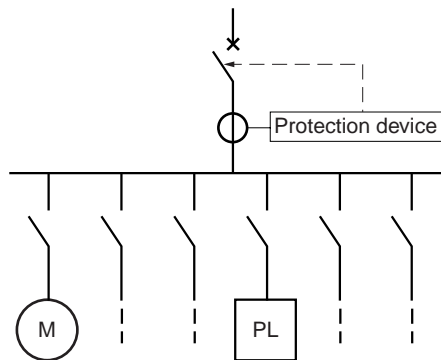

Fig. 35

■ Passive loads case

Consider as characteristic data the impedance load Z_{load} with a rated current I_{load} such that:

$$I_{load} = \frac{U}{\sqrt{3} Z_{load}}$$

$$Z_d = Z_i = Z_{load}$$

so

$$|I_2| = |I_3| = \frac{U}{2 \times Z_{load}}$$

$$= \frac{\sqrt{3}}{2} I_{load} \approx 0.87 I_{load}$$

$$|I_d| = |I_i| = \frac{I_{load}}{2} = 0.50 I_{load}$$

■ Motors case

Consider as motor characteristic data the impedance Z_{mot} with a rated current I_{mot} and a starting current I_{start} such that:

$$I_{start} = k I_{mot}$$

$$I_{mot} = U / \sqrt{3} Z_{mot}$$

Where for a standard motor $k \approx 5$.

□ In normal operation or no-load operation, the slip is low, $Z_d = Z_{mot}$ and $Z_i = Z_{start} = Z_{mot} / k$

so

$$|I_2| = |I_3| = \frac{U}{(Z_d + Z_i)} = \sqrt{3} I_{mot} \frac{k}{(1+k)}$$

as $k \approx 5$ then:

$$|I_1| = |I_2| \approx 1.44 I_{mot}$$

$$|I_d| = |I_i| = I_{mot} \times \frac{k}{(1+k)} \approx 0.83 I_{mot}$$

□ During load increase, the slip is high, $Z_d = Z_i = Z_{start} = Z_{mot} / k$

so

$$|I_1| = |I_2| = \frac{U}{(Z_d + Z_i)} = \sqrt{3} I_{mot} \times \frac{k}{2}$$

as $k \approx 5$ then:

$$|I_1| = |I_2| \approx 4.33 I_{mot}$$

$$|I_d| = |I_i| = I_{mot} \times \frac{k}{2} \approx 2.5 I_{mot}$$

■ Settings for the protection device relay

The setting for the incoming circuit-breaker must take the following constraints into consideration:

□ $I_{threshold} > I_{i_{max}}$ (maximum negative-sequence current in normal operation)

□ $I_{threshold} < I_{i_{min}}$ (minimum negative-sequence current on faulty feeder, ie. with an open phase)

Assuming a supply voltage unbalance of less than 2% ($V_{i_{max}} = 0.02 V$), the value of the minimum negative-sequence current in normal operation is:

□ For a passive load:

$$I_{i_{max}} = 0.02 I_{load}$$

□ For a motor:

$$I_{i_{max}} = V_{i_{max}} / Z_{i_{min}} = V_{i_{max}} / Z_{start} = 0.02 k I_{mot}$$

Where $k \approx 5$, $I_{i_{max}} \approx 0.1 I_{mot}$

The table below shows the threshold setting limits for the line protection devices.

Protection device setting	Individual passive load	Individual motor	Electrical switchboard for motors + passive loads
$I_{threshold}$ greater than ...	$0.02 I_{load}$	$0.1 I_{motor}$	$\sum I_{negative-sequence}$ in normal operation = $0.1 \sum I_{motor} + 0.02 \sum I_{load}$
$I_{threshold}$ less than ...	$0.5 I_{load}$	$0.83 I_{motor}$	$0.5 I_{load}$ for the smallest load or $0.83 I_{mot}$ for the smallest motor

4.5 Measuring the symmetrical components of a voltage and current system

Voltage system

■ The zero-sequence component is measured using three voltage transformers (VT), the primary windings connected between phase and neutral and the secondary windings connected in series to supply a voltmeter (see Fig. 36).

$V = 3 V_o k$ where $k =$ transformation ratio.

■ The positive-sequence component is measured using two voltage transformers installed between V_1 and V_2 and between V_2 and V_3 (see Fig. 37).

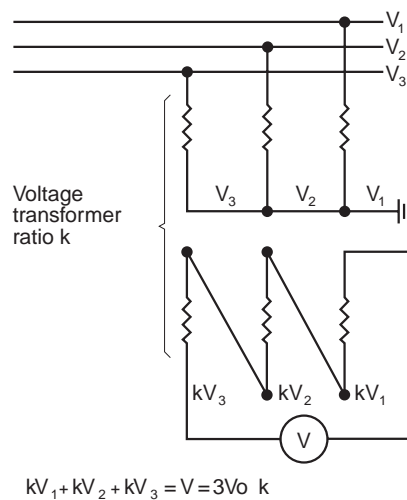

Fig. 36

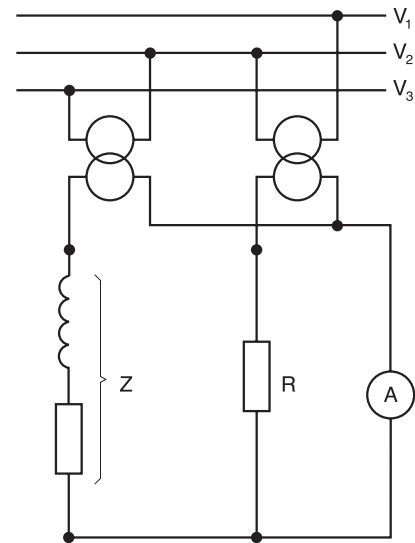

Fig. 37

The first voltage transformer is loaded by a resistor R . The second voltage transformer is loaded by an inductance and by a resistance such that:

$$Z = -a^2 R = R e^{j\frac{\pi}{3}}$$

Z comprises a resistance $\frac{R}{2}$ and a reactance

$R \frac{\sqrt{3}}{2}$ in series.

The two circuits are connected in parallel to an ammeter which measures a current proportional to:

$$\begin{aligned} (V_1 - V_2) + [-a^2(V_2 - V_3)] &= V_1 - V_2(1 + a^2) + a^2V_3 \\ &= V_1 + aV_2 + a^2V_3 = 3V_d \end{aligned}$$

■ The negative-sequence component is measured in the same way as the positive-sequence component but by inverting terminals 2 and 3.

$$\begin{aligned} (V_1 - V_3) + [-a^2(V_3 - V_2)] &= V_1 + a^2V_2 - V_3(1 + a^2) \\ &= V_1 + a^2V_2 + aV_3 = 3V_i \end{aligned}$$

Current system

■ The positive-sequence component is measured using three current transformers (CT) installed as shown in **Figure 38**.

Auxiliary transformer T2 supplies a current proportional to $(I_3 - I_2)$ across R.

Auxiliary transformer T1 supplies a current proportional to $(I_1 - I_3)$ across Z, which is equal to $-a^2 R$.

The voltage at the terminals of the voltmeter is proportional to:

$$\begin{aligned} (I_3 - I_2) + (I_1 - I_3)(-a^2) &= I_3 - I_2 - a^2 I_1 + a^2 I_3 \\ &= -a^2(I_1 + aI_2 + a^2 I_3) = 3a^2 I_d \end{aligned}$$

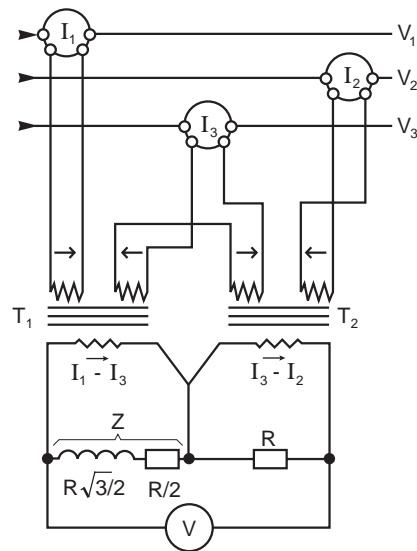

Fig. 38

■ The negative-sequence component is also measured using three current transformers, but installed as shown in **Figure 39**. Identical reasoning to that for the previous case shows that the voltage at the terminals of the voltmeter is proportional to

$$\begin{aligned} (I_1 - I_3) + (I_3 - I_2)(-a^2) &= I_1 + a^2 I_2 - I_3(a^2 + 1) \\ &= I_1 + a^2 I_2 + a I_3 = 3I_i \end{aligned}$$

■ The zero-sequence component is equal to one-third of the neutral current flowing directly into the ground connection (distributed neutral).

Three current transformers connected in parallel can be used to measure the component at ammeter A:

$$I_1 + I_2 + I_3 = I_h \text{ (see Fig. 40).}$$

A toroidal transformer surrounding all the active conductors can also be used to measure it by the vector sum of the phase currents.

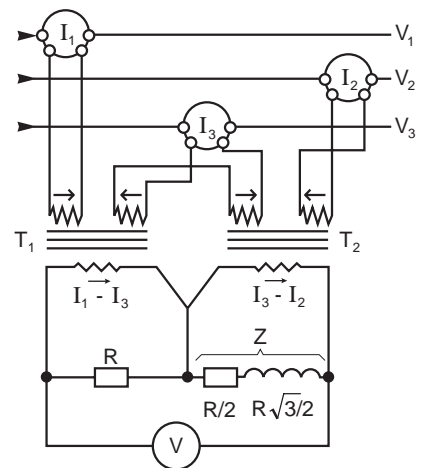

Fig. 39

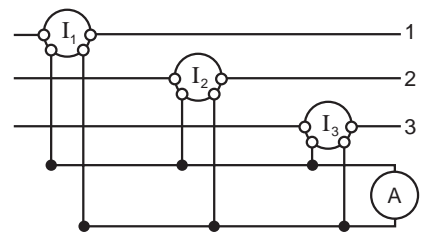

Fig. 40

Appendix: Zero-sequence reactance of transformers

Group		Equivalent single-line diagram	Value of the zero-sequence reactance of the transformer, seen from the	
Primary winding	Secondary winding		primary terminals 1	secondary terminals 2
			Infinite	Infinite
			Infinite	Infinite
			Fr. L.: infinite F. F.: $X_{11} = 10$ to 15 times X_{sc}	Fr. L.: infinite F. F.: infinite
			$X_{12} = X_{sc}$	$X_{12} = X_{sc}$
			Infinite	Infinite
			$X_{12} = X_{sc}$	Infinite
			Infinite	Infinite
			Infinite	$X_{22} = 1\%$ of S_n
			F. L.: infinite F. F.: $X_{11} = 10$ to 15 times X_{sc}	F. L.: infinite F. F.: infinite

Note:
Fr.L.: Free flux
F.F.: Forced flux

Group			Equivalent single-line diagram	Value of the zero-sequence reactance of the transformer, seen from the		
Primary	Secondary	Tertiary		primary terminals 1	secondary terminals 2	tertiary terminals 3
				Infinite	$X_{22} = 1\% \text{ of } X_n$	
				Fr. L.: infinite F. F.: $X_{11} = 10 \text{ to } 15 \text{ times } X_{sc}$	Fr. L.: $X_{22} = 1\% \text{ of } X_n$ F. F.: $X_{22} = 1\% \text{ of } X_n$	
				Infinite	Infinite	
				Fr. L.: infinite F. F.: $X_{11} = 10 \text{ to } 15 \text{ times } X_{sc}$	Infinite	Infinite
					$X_1 + \frac{(X_2 + X_{02})(X_3 + X_{03})}{X_2 + X_{02} + X_3 + X_{03}}$ $X_2 + \frac{(X_1 + X_{01})(X_3 + X_{03})}{X_1 + X_{01} + X_3 + X_{03}}$	$X_3 + \frac{(X_1 + X_{01})(X_2 + X_{02})}{X_1 + X_{01} + X_2 + X_{02}}$
				$X_1 + \frac{X_2 X_3}{X_2 + X_3}$	Infinite	Infinite
				$X_1 + \frac{X_2(X_3 + X_{03})}{X_2 + X_3 + X_{03}}$	Infinite	$X_3 + \frac{X_2(X_1 + X_{01})}{X_1 + X_2 + X_{01}}$
				$X_1 + X_2 = X_{12}$	Infinite	$X_{33} = 1\% \text{ of } X_n$

Note:
Fr.L.: Free flux
F.F.: Forced flux

Schneider Electric

Direction Scientifique et Technique,
Service Communication Technique
F-38050 Grenoble cedex 9
E-mail : fr-tech-com@schneider-electric.com

DTP: Axxess Valence.
Transl.: Lloyd International - Tarportey - Cheshire - GB
Editor: Schneider Electric