

Cahier technique no. 207

Electric motors

... and how to improve their control and protection

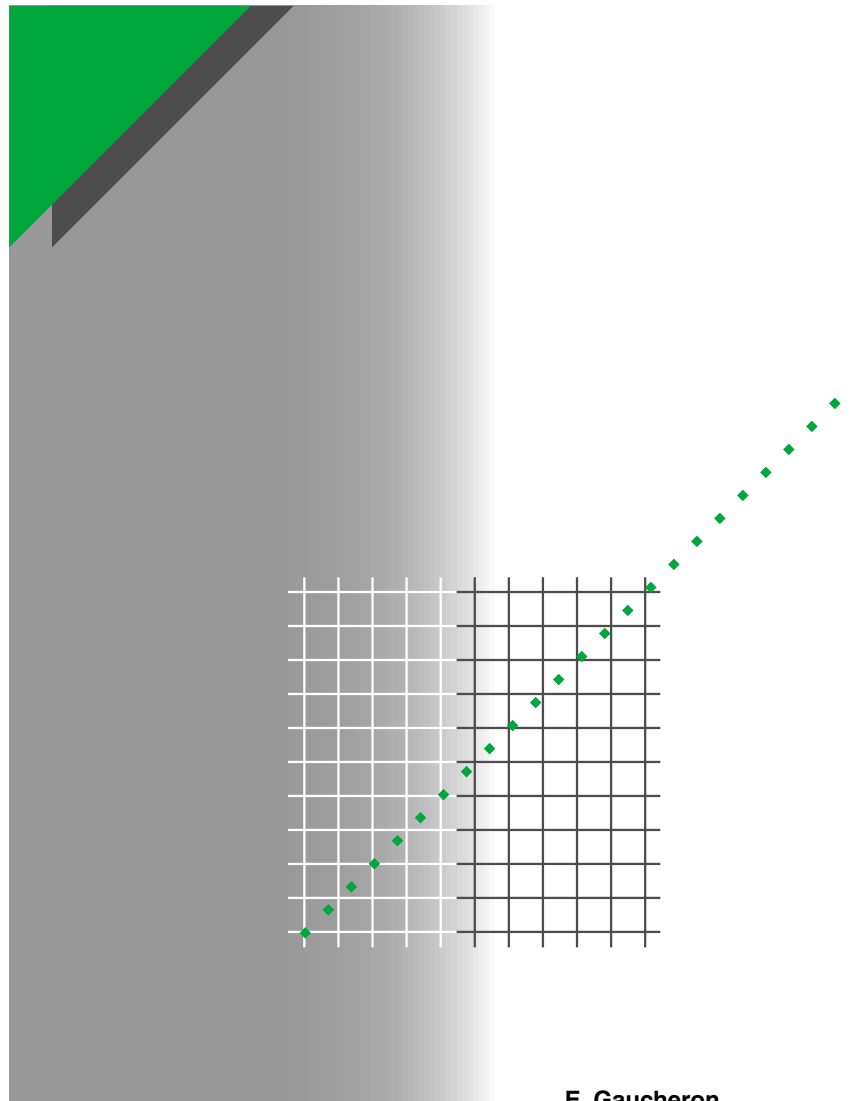

E. Gaucheron

"Cahiers Techniques" is a collection of documents intended for engineers and technicians, people in the industry who are looking for more in-depth information in order to complement that given in product catalogues.

Furthermore, these "Cahiers Techniques" are often considered as helpful "tools" for training courses.

They provide knowledge on new technical and technological developments in the electrotechnical field and electronics. They also provide better understanding of various phenomena observed in electrical installations, systems and equipments.

Each "Cahier Technique" provides an in-depth study of a precise subject in the fields of electrical networks, protection devices, monitoring and control and industrial automation systems.

The latest publications can be downloaded from the Schneider Electric internet web site.

Code: <http://www.schneider-electric.com>

Section: **Press**

Please contact your Schneider Electric representative if you want either a "Cahier Technique" or the list of available titles.

The "Cahiers Techniques" collection is part of the Schneider Electric's "Collection technique".

Foreword

The author disclaims all responsibility subsequent to incorrect use of information or diagrams reproduced in this document, and cannot be held responsible for any errors or oversights, or for the consequences of using information and diagrams contained in this document.

Reproduction of all or part of a "Cahier Technique" is authorised with the compulsory mention:

"Extracted from Schneider Electric "Cahier Technique" no." (please specify).

no. 207

Electric motors

... and how to improve their control and protection

Etienne Gaucheron



Graduate electronics engineer by training. After a short period with Thomson he joined the VsD (Variable speed drives and starters) division of Telemecanique in 1970. He then completed his training at ENSAM (the national college for arts and vocational training) in Paris during his position with Telemecanique's after sales service. As a specialist in motor control, he was involved in the development of variable speed control for AC motors. He has gained a wide range of experience in various positions: systems platform engineer, product manager for machine tool drive products, product manager for drives for asynchronous motors (Altivar products) and manager of the VSD project marketing team. He is currently a motor control "applications" specialist within the advance development team for the Schneider Electric PCP (Power Control and Protection) division.

Electric motors

... and how to improve their control and protection

Nowadays, apart from lighting devices, electric motors represent the largest loads in industry and commercial installations. Their function, to convert electrical energy into mechanical energy, means they are particularly significant in economic terms, and hence, they cannot be ignored by installation or machinery designers, installers or users.

There are many types of motor in existence, but 3-phase asynchronous motors, and in particular squirrel cage motors, are the most commonly used in industry and in commercial buildings applications above a certain power level. Moreover, although they are ideal for many applications when controlled by contactor devices, the increasing use of electronic equipment is widening their field of application. This is the case for start/stop control with soft start/soft stop units, and when precise speed adjustment is also necessary with variable speed drives/regulators.

However, slip-ring asynchronous motors are used for certain high power applications in industry, and single phase asynchronous motors remain suitable for limited power applications, mainly for buildings applications.

The use of synchronous motors, known as brushless or permanent magnet motors, combined with converters is becoming increasingly common in applications requiring high performance levels, in particular in terms of dynamic torque (on starting or on a change of duty), precision and speed range.

After presenting the various types of electric motor and their operating principles, this "Cahier Technique" describes the technical and operating features of asynchronous motors, covering in particular the main starting devices, speed control and braking methods. It provides a solid grounding for the reader to gain a good understanding of all the problems involved with motor control and protection.

This "Cahier Technique" touches briefly on variable speed control of electric motors. However, this subject is covered more specifically in "Cahier Technique" CT 208 "Electronic starters and variable speed drives". Motor protection is the subject of another "Cahier Technique" currently in preparation.

Contents

1 Three-phase asynchronous motors	1.1 Operating principle	p. 4
	1.2 Construction	p. 6
	1.3 The various types of rotor	p. 6
2 Other types of electric motor	2.1 Single phase asynchronous motors	p. 10
	2.2 Synchronous motors	p. 10
	2.3 DC motors	p. 14
3 Operation of asynchronous motors	3.1 Squirrel cage motors	p. 17
	3.2 Slip-ring motors	p. 19
	3.3 Other speed variation systems	p. 20
4 Conclusion		p. 22

1 Three-phase asynchronous motors

This section covers 3-phase asynchronous motors, the most commonly used motors for driving machinery. The use of this type of motor has become the norm in a large number of applications because of its numerous advantages: it is standardized, rugged, easy to maintain and use, and inexpensive.

1.1 Operating principle

The operating principle of an asynchronous motor is based on the creation of an induced current in a conductor when the conductor cuts the lines of a magnetic field, hence the name "induction motor". The combined action of this induced current and the magnetic field creates a motive force on the motor rotor. Let us take the example of a turn with short circuit ABCD, located in magnetic field B, and rotating around an axis xy (see Fig. 1).

If, for example, we rotate the magnetic field clockwise, the turn is subject to a variable flux and becomes the source of an induced electromotive force which causes an induced current I (Faraday's law).

According to Lenz's law, the direction of the current is such that it opposes the cause that produced it by its electromagnetic action. Both of

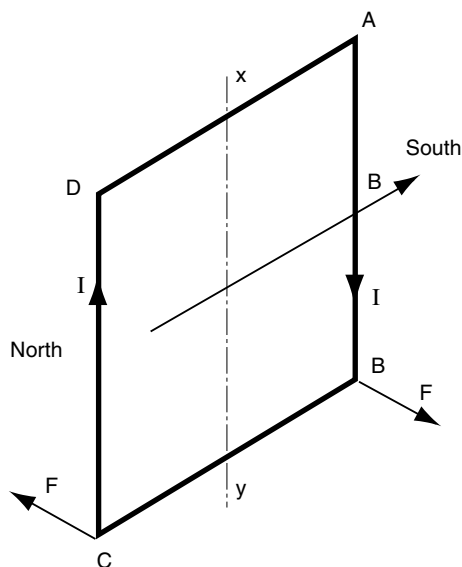

Fig. 1: Creation of an induced current in a shorted turn

Other types of motor are presented in section 2. Section 3 describes and compares the main starting devices, and speed control and braking methods associated with the motors.

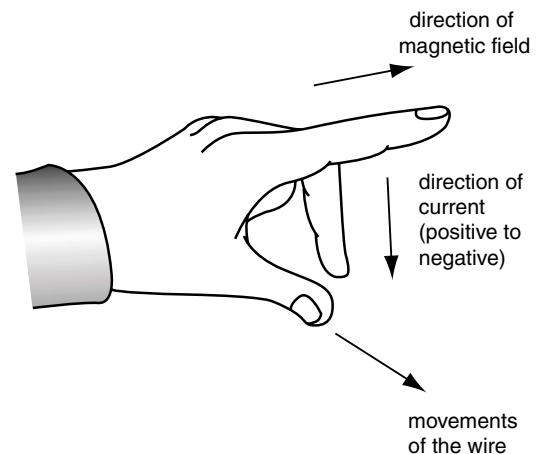

Fig. 2: Fleming's left hand rule to find the direction of the force

the conductors are therefore subject to a Lorentz force F (also known as Laplace force), in the opposite direction to its relative displacement in relation to the field coil field.

The left hand rule (action of the field on a current, see Figure 2) helps demonstrate the direction of the force F applied to each conductor.

The thumb points in the direction of the movement field. The index finger indicates the direction of the field. The middle finger points in the direction of the induced current. The turn is therefore subject to a torque that causes it to rotate in the same direction as the coil field, called the rotating field. The turn therefore starts to rotate and the electromotive torque produced balances the resistive torque.

Creation of the rotating field

Three windings, geometrically offset by 120°, are each supplied by one of the phases of a 3-phase

AC supply (see Fig. 3). The windings have AC currents flowing through them that have the same electrical offset and that each produce a sinusoidal AC magnetic field. This field, which always follows the same axis, is at its maximum when the current in the winding is at its maximum.

The field generated by each winding is the resultant of two fields rotating in opposite directions, each field having a constant value of

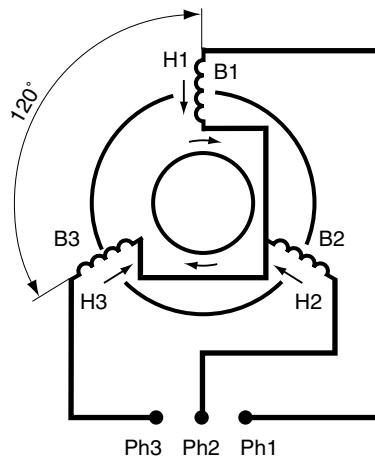

Fig. 3: Principle of a 3-phase asynchronous motor

half that of the maximum field. At any instant t_1 in the period (see Fig. 4), the fields produced by each winding can be represented as follows:

- Field H1 decreases. Its two component fields tend to move away from the axis OH1.
- Field H2 increases. Its two component fields tend to move towards the axis OH2.
- Field H3 increases. Its two component fields tend to move towards the axis OH3.

The flux corresponding to phase 3 is negative. The field is thus directed in the opposite direction to the coil.

If the three diagrams are superimposed, it can be seen that:

- The three fields rotating anticlockwise are offset by 120° and cancel one another out.
- The three fields rotating clockwise are superimposed on one another. These fields are added together to form the rotating field with constant amplitude $3H_{max}/2$. It is a field with one pair of poles.

This field performs one rotation during one period of the supply current. Its speed is dependent on the line supply frequency (f), and the number of pairs of poles (p). It is called the "synchronous speed".

Slip

Motor torque can only exist if there is an induced current flowing in the turn. This torque is determined by the current flowing in the turn and can only exist if there is flux variation in this turn. There must therefore be a difference in speed between the turn and the rotating field. This is why an electric motor operating according to the principle we have just described is called an "asynchronous motor". The difference between the synchronous speed (N_s) and that of the turn (N) is called the "slip" and is expressed as a percentage of the synchronous speed.

$$\text{slip} = \frac{(N_s - N)}{N_s} \times 100$$

During operation, the rotor current frequency is obtained by multiplying the supply frequency by the slip. The rotor current frequency is therefore at its maximum on starting.

The steady state slip varies according to the motor load and the level of the supply voltage applied to it: the lower the motor load, the lower the slip; and if the motor is under-supplied the slip increases.

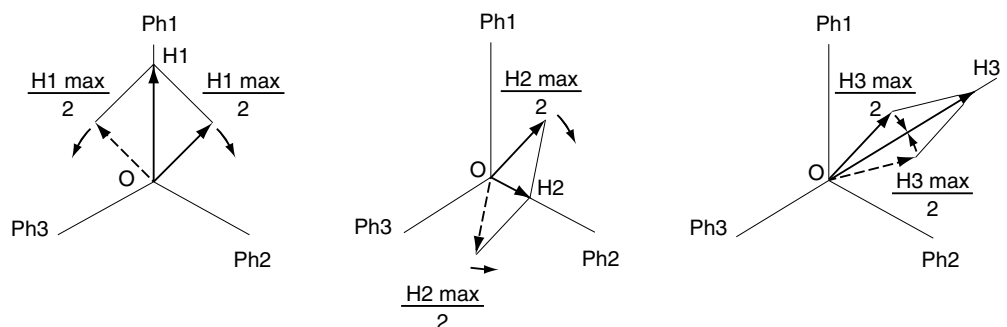

Fig. 4: Fields generated by the three phases

Synchronous speed

The synchronous speed of 3-phase asynchronous motors is directly proportional to the supply current frequency and inversely proportional to the number of pairs of poles comprising the stator.

For example:

$$N_s = 60 f/p$$

Where:

- N_s : synchronous speed in rpm
- f : frequency in Hz
- p : number of pairs of poles

The rotation speeds of the rotating field, or synchronous speeds, according to the number of poles, are given in the table in **Figure 5** for industrial frequencies of 50 Hz and 60 Hz and one other frequency (100 Hz).

In practice it is not always possible to increase the speed of an asynchronous motor by supplying it with a higher frequency than that for which it is designed, even if the voltage is suitable. It is therefore necessary to check whether its mechanical and electrical design allows this.

Number of poles	Speed of rotation in rpm		
	50 Hz	60 Hz	100 Hz
2	3000	3600	6000
4	1500	1800	3000
6	1000	1200	2000
8	750	900	1500
10	600	720	1200
12	500	600	1000
16	375	540	750

Fig. 5: Synchronous speeds according to the number of poles and the current frequency

It should be noted that in view of the slip, the on-load rotation speeds of asynchronous motors are slightly lower than the synchronous speeds indicated in the table.

1.2. Construction

A 3-phase squirrel cage asynchronous motor consists of two main parts: a field coil or stator and an armature or rotor.

Stator

This is the fixed part of the motor. A cast iron or light alloy frame surrounds a ring of thin laminations (around 0.5 mm thick) made of silicon steel. The laminations are insulated from one another by oxidation or an insulating varnish. The "lamination" of the magnetic circuit reduces losses via hysteresis and eddy currents. The laminations have slots in them for holding the stator windings that produce the rotating field (three windings for a 3-phase motor). Each

winding is made up of a number of coils. The way these coils are joined to one another defines the number of pairs of poles of the motor, and thus the speed of rotation.

Rotor

This is the moving part of the motor. Like the magnetic circuit of the stator, it is made up of a stack of thin laminations insulated from one another, forming a keyed cylinder on the motor shaft. Two different technologies can be used for this part, which separate asynchronous motors into two distinct families: those with a "squirrel cage" rotor and those with a wound rotor which are referred to as "slip-ring".

1.3. The various types of rotor

Squirrel cage rotor

There are several types of squirrel cage rotor. They are all designed as shown in the example in **Figure 6**.

These motors are (from the least common to the most widely used):

- Resistive squirrel cage rotor

The resistive rotor mainly exists in the single cage version (see later for the definition of the

single cage motor). The cage is closed by two resistive rings (special alloy, small cross-section, stainless steel rings, etc). These motors have high slip at nominal torque. Their starting torque is high and the starting current is low (see **Fig. 7**). The efficiency of these motors is low due to the losses in the rotor.

This type of motor is mainly used for applications in which it is useful to have some

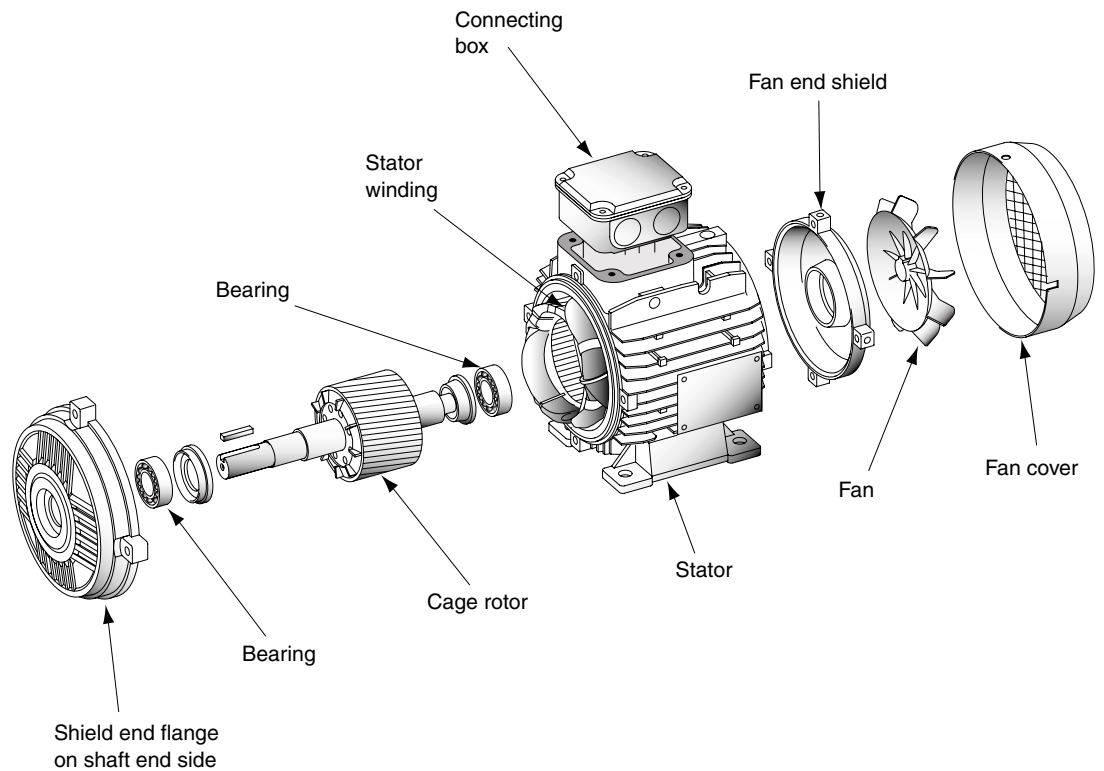

Fig. 6: Exploded view of a squirrel cage rotor motor

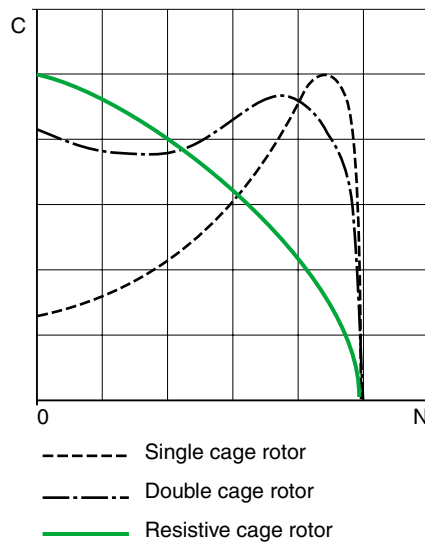

Fig. 7: Torque/speed curves for the various types of cage rotor (at U_n)

slip in order to adapt the speed to the torque, for example:

- In the case of several motors connected mechanically, across which the load must be distributed, such as rolling mill roller tables, or the drive system of a lifting crane
- For winder/unwinder functions using Alquist⁽¹⁾ motors designed for this purpose
- When a high starting torque with limited inrush current is needed (lifting hoists or conveyors).

They are used to control the speed by modifying the voltage alone. But this application is on the decline, being increasingly replaced by frequency inverters. Although, in general, motors are self-cooled, some resistive squirrel cage motors are force-cooled (separate motorization of their fans).

1. This force-cooled asynchronous motor with high slip is used in speed control. Its stalling current is close to its nominal current, and its torque/speed characteristic falls very steeply. With a variable power supply it is possible to adapt this characteristic and adjust the motor torque according to the required traction.

■ Single squirrel cage rotor

Conductors are placed in the holes or slots around the edges of the rotor (on the outside of the cylinder created by the stacking of the laminations) and connected at either end by a metal ring. The motor torque generated by the rotating field is applied to these conductors. To make the torque regular, the conductors are at a slight angle in relation to the motor shaft. The whole assembly resembles a squirrel cage, hence the name of this type of rotor.

The squirrel cage is generally fully molded, (only very large motors are made with conductors inserted in slots). Aluminum is pressure injected and the cooling fins, which are cast in the same operation, are used for short-circuiting the stator conductors.

These motors have a relatively low starting torque and the current drawn on power-up is much higher than the nominal current (see Figure 7).

On the other hand they have low slip at nominal current.

These motors are mainly used at high power to improve the efficiency of installations on pumps and fans. They are also used with frequency inverters at variable speed. The torque and current problems on starting are thus fully resolved.

■ Double squirrel cage rotor

This consists of two concentric cages, one outer, with a small cross-section, and highly resistive, and the other inner, with a large cross-section and lower resistance.

□ At the beginning of the starting phase, when the rotor current frequency is high, the resulting skin effect causes the whole of the rotor current to flow around the outer surface of the rotor and thus in a smaller surface area of the conductors. Thus, at the beginning of the starting phase, when the rotor current frequency is high, the current only flows in the outer cage. The torque produced by the resistive outer cage is high and the current inrush low (see Fig. 7).

□ At the end of the starting phase, the frequency decreases in the rotor and it is easier for the flux to flow through the inner cage. The motor then

behaves very much as if it had been built with a single low resistance cage.

In steady state the speed is only slightly lower than that of a single cage motor.

■ Rotor with deep slots

This is the standard version.

The rotor conductors are molded into the rotor slots which are trapezoidal shape, with the small side of the trapeze located on the outer surface of the rotor.

Operation is similar to that of a double cage motor: the intensity of the rotor current varies inversely to its frequency. Thus:

□ At the beginning of the starting phase, torque is high and the current inrush is low.

□ In steady state the speed is more or less the same as that of a single cage motor.

Wound rotor (slip-ring rotor)

Identical windings to those of the stator are inserted in the slots around the outer edge of the rotor (see Fig. 8). The rotor is generally 3-phase.

One end of each of the windings is connected to a common point (star connection). The free ends can be connected to a centrifugal switch or to three insulated solid copper rings that form part of the rotor. The graphite-based brushes connected to the starting device rub against these rings.

Depending on the values of the resistors inserted in the rotor circuit, this type of motor can develop a starting torque of up to 2.5 times the nominal torque.

The current on starting is more or less proportional to the torque developed on the motor shaft.

This solution is now being phased out in favor of electronic solutions combined with a standard squirrel cage motor. In fact, the latter solutions resolve maintenance issues (replacement of worn rotor power supply brushes, servicing of adjustment resistors), reduce the energy dissipated in these resistors and also significantly improve the efficiency of the installation.

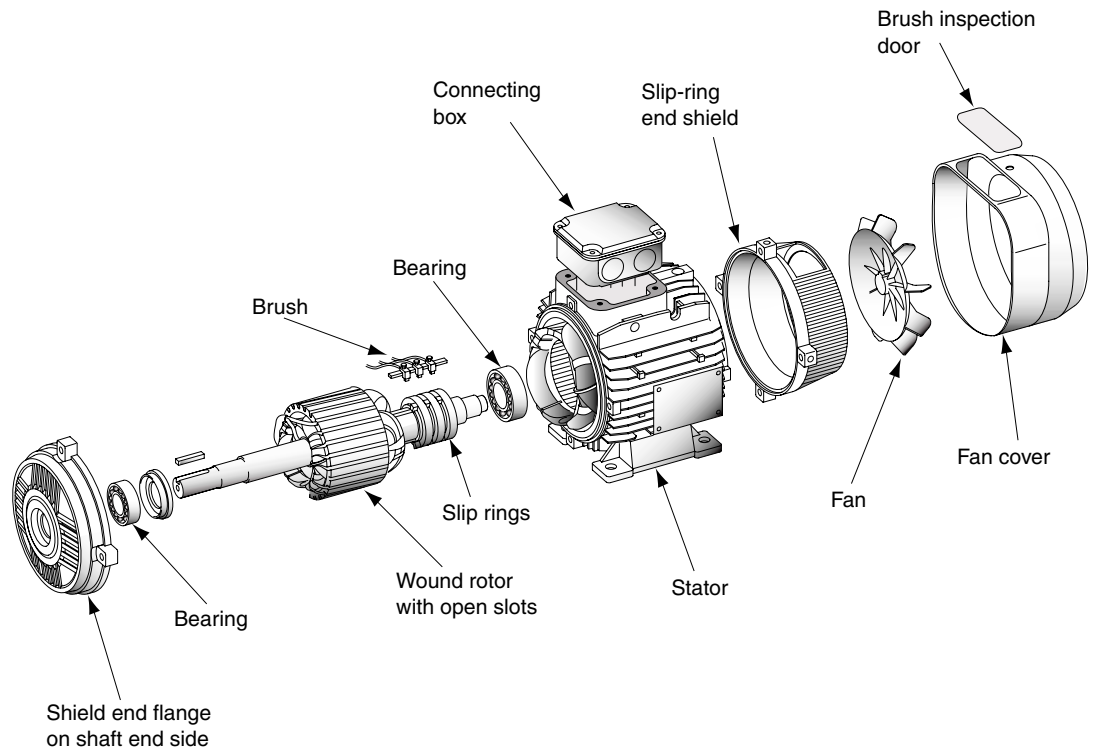

Fig. 8: Exploded view of a slip-ring rotor moto

2 Other types of electric motor

2.1 Single phase asynchronous motors

Although the single phase asynchronous motor is less widely used in industry than its 3-phase counterpart, it nevertheless represents a significant proportion of low power and buildings applications that use a 230 V single phase line supply.

It is more bulky than a 3-phase motor of the same power rating.

Moreover, its efficiency and its power factor are much lower than with the 3-phase motor and they vary considerably depending on the power and the manufacturer.

Single phase motors up to ten or so kW are widely used in the United States.

Construction

Like the 3-phase motor, the single phase motor consists of two parts: the stator and the rotor.

■ Stator

This consists of an even number of poles and its coils are connected to the line supply.

■ Rotor

More often than not this is a squirrel cage rotor.

Operating principle

Let us consider a stator consisting of two windings, L1 and N, connected to the line supply (see Fig. 9).

The single phase AC current creates a single AC field H in the rotor, which is the superimposition of two rotating fields H1 and H2 with the same value rotating in opposite directions.

On stopping, because the stator is energized, these fields have the same slip in relation to the

rotor and consequently produce two equal and opposite torques. The motor cannot start. A mechanical pulse on the rotor causes the slips to become unequal. One of the torques decreases while the other increases. The resulting torque causes the motor to start in the direction in which it has been set going.

In order to solve this torque problem during the starting phase, a second coil, offset by 90° , is inserted in the stator. This auxiliary phase is powered by a phase angle device (capacitor or inductance). Once starting is complete the auxiliary phase can be disabled.

Note: A 3-phase motor can also be used in single phase operation. The starting capacitor is then connected in series or in parallel with the unused winding.

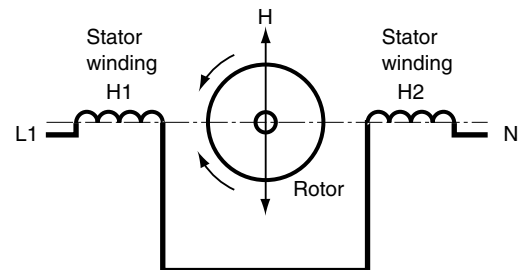

Fig. 9: Operating principle of a single phase asynchronous motor

2.2 Synchronous motors

Construction

Like the asynchronous motor, the synchronous motor consists of a stator and a rotor separated by the air gap. It differs from the asynchronous motor in that the flux in the air gap is not due to a component of the stator current: it is created by magnets or by the field coil current provided by an external DC source energizing a winding placed in the rotor.

■ Stator

The stator consists of a housing and a magnetic circuit generally comprising silicon steel

laminations and a 3-phase coil similar to that of an asynchronous motor supplied with 3-phase AC to produce a rotating field.

■ Rotor

The rotor carries field magnets or coils through which a direct current flows and which create interposed North and South poles. Unlike asynchronous machines, the rotor rotates with no slip at the speed of the rotating field.

There are therefore two different types of synchronous motor: magnet motors and wound rotor motors.

□ With magnet motors, the motor rotor is fitted with permanent magnets (see Fig. 10) (generally rare earth magnets), in order to achieve increased field strength in a small volume. The stator has three-phase windings. These motors can tolerate significant overload currents in order to achieve high-speed acceleration. They are always used with a variable speed drive, and these motor-drive assemblies are intended for specific markets such as robots or machine tools, for which smaller motors, acceleration and passband are essential.

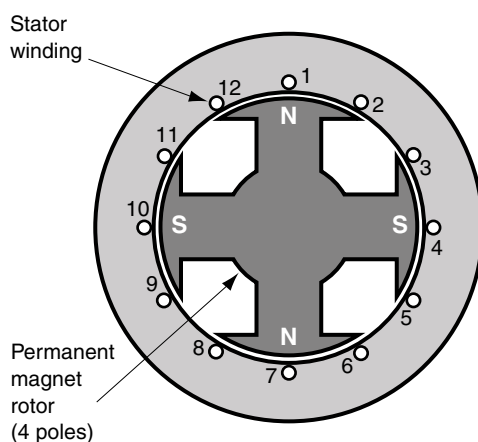

Fig. 10: Cross-section of a permanent magnet motor

□ The second type of synchronous machine has a wound coil, and is a reversible machine that can operate as either a generator (alternator) or a motor. For many years these machines have been mainly used as alternators. Their use as motors was virtually confined to applications where it was necessary to drive loads at fixed speed despite relatively wide variations in their resistive torque.

The development of direct (cycloconverters) or indirect frequency inverters operating with natural switching due to the ability of synchronous machines to provide reactive power, has enabled the creation of high performance, reliable variable speed electric drives that are particularly competitive in relation to competitors' solutions for power ratings over one megawatt.

Although it is possible to find synchronous motors used industrially in power ratings ranging from 150 kW to 5 MW, it is above 5 MW that electric drives using synchronous motors become virtually essential, for the most part combined with variable speed drives.

Operating characteristics

The motor torque of the synchronous machine is proportional to the voltage at its terminals, whereas that of the asynchronous machine is proportional to the square of that voltage.

Unlike the asynchronous motor, it can work with a power factor equal to one or very close to it.

The synchronous motor therefore has a number of advantages over the asynchronous motor with regard to its ability to be powered via the constant voltage/frequency line supply:

□ The speed of the motor is constant, regardless of the load.

□ It can supply reactive power and increase the power factor of an installation.

□ It can withstand relatively large voltage drops (around 50% due to its over-excitation properties) without stalling.

However, the synchronous motor supplied directly by the constant voltage/frequency line supply has two disadvantages:

□ It has starting difficulties. If the motor is not combined with a variable speed drive, starting must be performed at no-load, either by DOL starting for small motors, or using a starting motor that drives it at a speed close to synchronous speed before direct connection to the line supply.

□ It may stall if the resistive torque exceeds its maximum electromagnetic torque. In this case, the entire start process must be repeated.

Other types of synchronous motor

To conclude this overview of industrial motors, we must also mention linear motors, synchronized asynchronous motors and stepper motors.

■ Linear motors

Their structure is identical to that of synchronous rotary motors: they consist of a stator (plate) and a rotor (forcer) which are in line. In general the plate moves along the forcer on a guide.

This type of motor does away with all intermediate kinematics for converting the movement, which means there is no play or mechanical wear on this drive.

■ Synchronized asynchronous motors

These are induction motors. During the starting phase, the motor operates in asynchronous mode and when it has reached a speed close to synchronous speed, it switches to synchronous mode.

If it has a high mechanical load, it can no longer operate in synchronous mode and returns to asynchronous mode. This feature is obtained by special construction of the rotor and is generally for low power motors.

■ Stepper motors

The stepper motor is a motor that operates according to the electrical pulses supplying its coils. Depending on its electrical power supply, it may be:

□ Unipolar if its coils are always supplied in the same direction by a single voltage, hence the name unipolar.

□ Bipolar when its coils are supplied sometimes in one direction and sometimes in the other. They sometimes create a North pole, and sometimes a South pole, hence the name bipolar.

Stepper motors can be of variable reluctance or magnet type or a combination of the two (see Fig. 11).

The minimum angle of rotation between two modifications of the electrical pulses is called a step. A motor is characterized by the number of steps per revolution (that is, for 360°). The most common values are 48, 100 or 200 steps per revolution.

The motor therefore rotates discontinuously. To improve the resolution, the number of steps may be increased in a purely electronic way (micro-step operation). By varying the current in the coils in steps (see Fig. 12), a resulting field is created that slides from one step to another, thus effectively reducing the step.

The circuits for micro-steps multiply the number of motor steps by 500, thus changing, for example, from 200 to 100,000 steps.

The electronics can be used to control the chronology of these pulses and count the number of pulses. Stepper motors and their control circuits thus enable a shaft to rotate with a high degree of precision in terms of both speed and amplitude.

Their operation is thus similar to that of a synchronous motor when the shaft is rotating continuously, which corresponds to specified frequency, torque and driven load inertia limits (see Fig. 13). If these limits are exceeded, the motor stalls, the effect of which is to stop the motor.

Type	Permanent magnet bipolar	Variable reluctance unipolar	Hybrid bipolar
Characteristics	2 phases, 4 wires	4 phases, 8 wires	2 phases, 4 wires
No. of steps/rev.	8	24	12
Operating stages			
Step 1			
Intermediate state			
Step 2			

Fig. 11: The three types of stepper motor

Accurate angular positioning is possible without a measurement loop. The small models of these motors, generally with power ratings of less than one kW, have a low voltage power supply. In industry, these motors are used for position control applications such as setting stops for cutting to length, controlling valves, optical or measurement devices, loading and unloading presses or machine tools, etc.

The simplicity of this solution makes it particularly economical (no feedback loop). Magnet stepper motors also have the advantage of a standstill torque when there is no power supply. On the other hand, the initial position of the moving part has to be known and taken into account by the electronics in order to provide effective control.

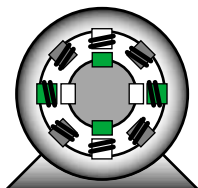
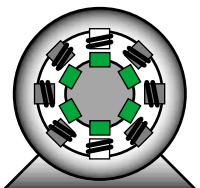
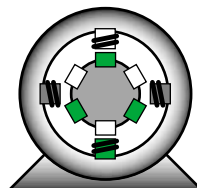
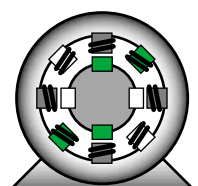
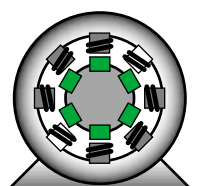
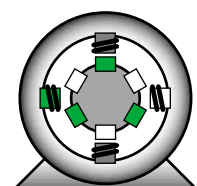
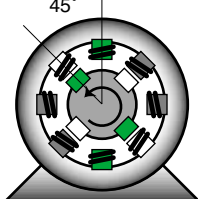
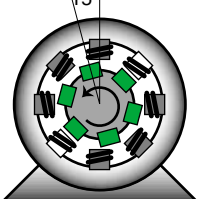
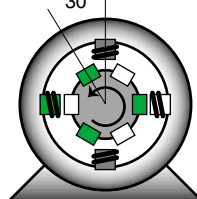
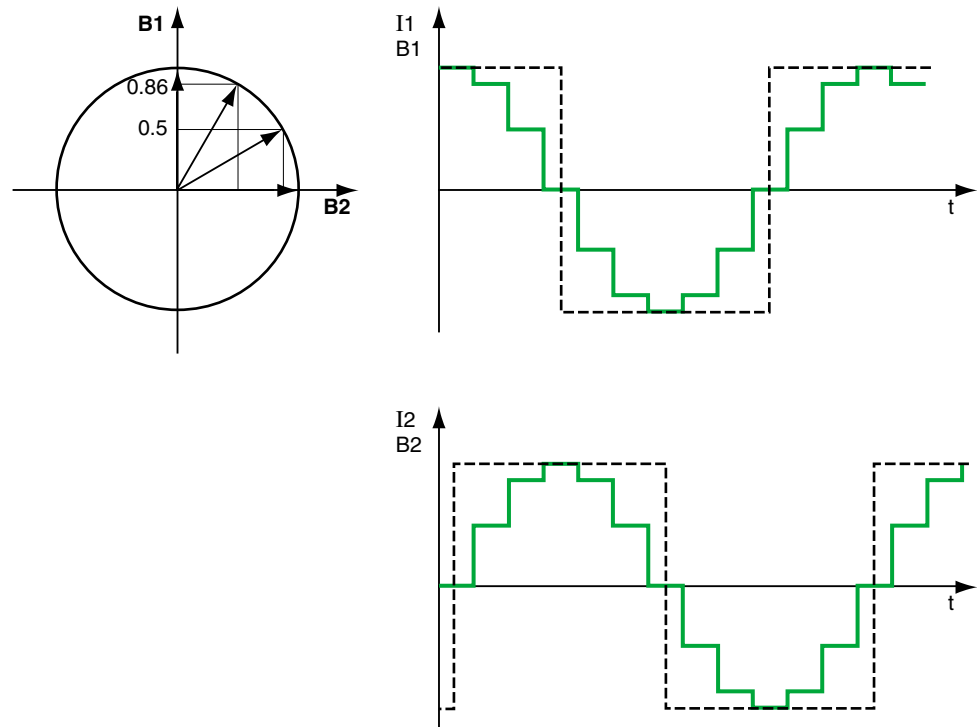

Fig. 12: Current steps applied to the coils of a stepper motor to reduce its step

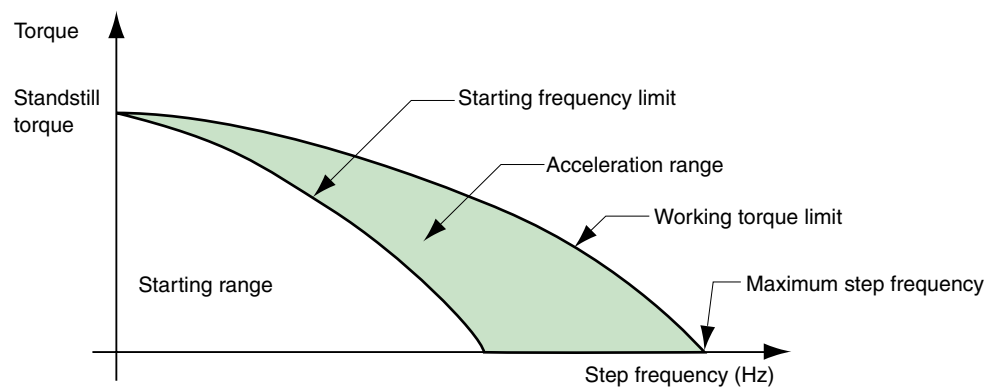

Fig. 13: Maximum torque according to step frequency

2.3 DC motors

Separate field excitation DC motors are still sometimes used for driving machines at variable speed.

These motors are very easy to miniaturize, and essential for very low powers and low voltages. They are also particularly suitable, up to high power levels (several megawatts), for speed variation with simple, uncomplicated electronic technologies for high performance levels (variation range commonly used from 1 to 100).

Their characteristics also enable accurate torque regulation, when operating as a motor or as a generator. Their nominal rotation speed, which is independent of the line supply frequency, is easy to adapt by design to suit all applications.

They are however less rugged than asynchronous motors and much more expensive, in terms of both hardware and maintenance costs, as they require regular servicing of the commutator and the brushes.

Construction

A DC motor is composed of the following parts:

- Field coil or stator

This is a non-moving part of the magnetic circuit on which a winding is wound in order to produce a magnetic field. The electro-magnet that is created has a cylindrical cavity between its poles.

- Armature or rotor

This is a cylinder of magnetic laminations that are insulated from one another and perpendicular to the axis of the cylinder. The armature is a moving part that rotates round its axis, and is separated from the field coil by an air gap. Conductors are evenly distributed around its outer surface.

- Commutator and brushes

The commutator is integral with the armature. The brushes are fixed. They rub against the commutator and thus supply power to the armature conductors.

Operating principle

When the field coil is energized, it creates a magnetic field (excitation flux) in the air gap, in the direction of the radii of the armature. This magnetic field "enters" the armature from the North pole side of the field coil and "exits" the armature from the South pole side of the field coil.

When the armature is energized, currents pass through the conductors located under one field coil pole (on the same side of the brushes) in the

same direction and are thus, according to Laplace's law, subject to a force. The conductors located under the other pole are subject to a force of the same intensity in the opposite direction. The two forces create a torque which causes the motor armature to rotate (see Fig. 14).

When the motor armature is powered by a DC or rectified voltage supply U , it produces back emf E whose value is $E = U - RI$

RI represents the ohmic voltage drop in the armature.

The back emf E is linked to the speed and the excitation by the equation $E = k \omega \Phi$ in which:

- k is a constant specific to the motor

- ω is the angular speed

- Φ is the flux

This equation shows that at constant excitation the back emf E (proportional to ω) is an image of the speed.

The torque is linked to the field coil flux and the current in the armature by the equation:

$$T = k \Phi I$$

If the flux is reduced, the torque decreases.

There are two methods for increasing the speed.

- Either increase the back emf E , and thus the supply voltage at constant excitation: this is known as "constant torque" operation.

- Or decrease the excitation flux, and thus the excitation current, while keeping the supply voltage constant: this is known as "reduced flux" or "constant power" operation. This operation requires the torque to decrease as the speed increases (see Fig. 15). However, for high reduced flux ratios this operation requires

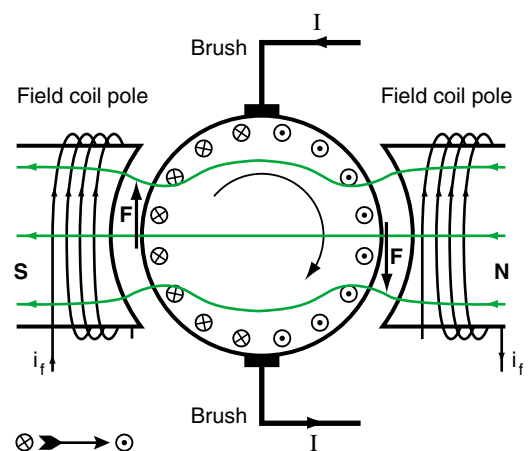

Fig. 14: Production of torque in a DC motor

specially adapted motors (mechanically and electrically) to overcome switching problems.

The operation of this type of device (DC motor) is reversible:

- If the load opposes the rotation movement (the load is said to be resistive), the device provides a torque and operates as a motor.
- If the load is such that it tends to make the device rotate (the load is said to be driving) or it opposes the slow-down (stopping phase of a

load with a certain inertia), the device provides electrical energy and operates as a generator.

Various types of DC motor (see Fig. 16)

- **Parallel excitation (separate or shunt)**
The coils, armature and field coil are connected in parallel or supplied via two sources with different voltages in order to adapt to the characteristics of the machine (e.g.: armature voltage 400 volts and field coil voltage 180 volts).

a: At constant torque

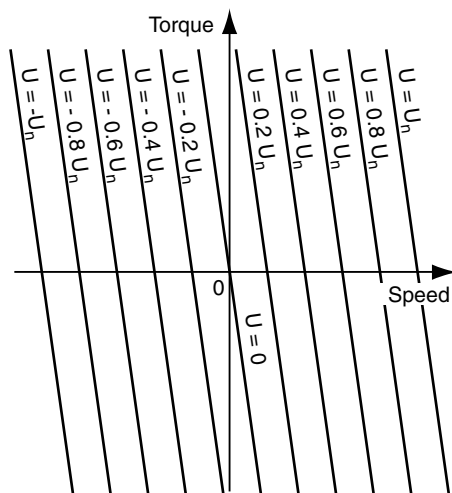

b: At constant power

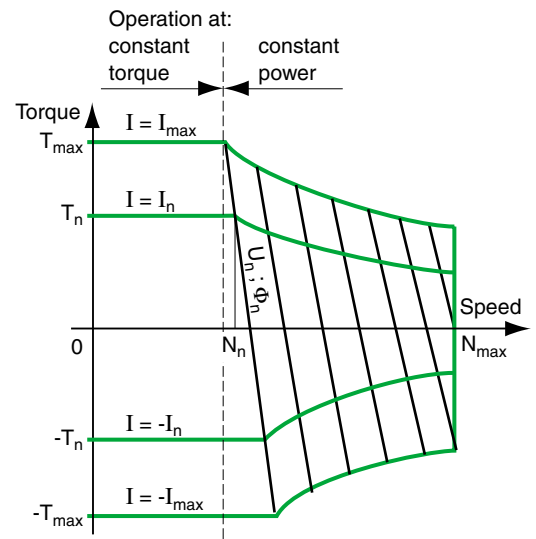
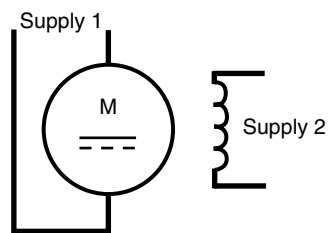
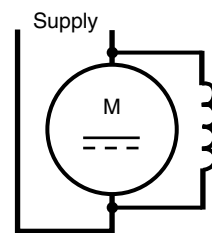

Fig. 15: Torque/speed curves for a separate field excitation motor

a: Separate field excitation motor



c: Shunt wound motor



b: Series wound motor

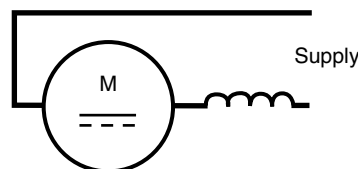

d: Compound wound motor

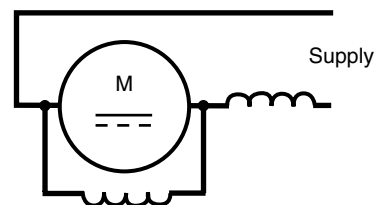

Fig. 16: Diagrams of the various types of DC motor

The direction of rotation is reversed by inverting one or other of the windings, generally by inverting the armature voltage due to the much lower time constants. Most bidirectional speed drives for DC motors operate in this way.

■ Series wound

The design of this motor is similar to that of the separate field excitation motor. The field coil is connected in series to the armature coil, hence its name.

The direction of rotation can be reversed by inverting the polarities of the armature or the field coil. This motor is mainly used for traction, in particular on trucks supplied by battery packs. In railway traction the old TGV (French high-speed

train) motor coaches used this type of motor. More recent coaches use asynchronous motors.

■ Compound wound (series-parallel excitation)

This technology combines the qualities of the series wound motor and the shunt wound motor.

This motor has two windings per field coil pole. One is connected in parallel with the armature. A low current (low in relation to the working current) flows through it. The other is connected in series.

It is an added flux motor if the ampere turns of the two windings add their effects. Otherwise it is a negative flux motor. But this particular mounting method is very rarely used as it leads to unstable operation with high loads.

3 Operation of asynchronous motors

3.1 Squirrel cage motors

Consequences of a voltage variation

■ Effect on the starting current

The starting current varies with the supply voltage. If the supply voltage is higher during the starting phase, the current drawn at the moment of power-up increases. This current increase is aggravated by the saturation of the machine.

■ Effect on the speed

When there are voltage variations, the synchronous speed is not modified, but for a motor under load, an increase in the voltage results in a slight decrease in the slip. In practical terms, this property cannot be used as, due to the saturation of the stator's magnetic circuit, the current drawn increases significantly that may cause an abnormal temperature rise of the machine, even during operation with a low load. On the other hand, if the supply voltage decreases, the slip increases, and the current drawn increases to provide the torque, with the resulting risk of temperature rise. Moreover, since the maximum torque decreases as the square of the voltage, the motor may stall if there is a significant decrease in the voltage.

Consequences of a frequency variation

■ Effect on the torque

As with any electrical machine, the torque of the asynchronous motor is of the type

$$T = K I \Phi$$

(K = constant coefficient depending on the machine)

In the equivalent diagram in **figure 17**, coil L is that which produces the flux and I_0 is the magnetizing current.

At first approximation, disregarding the resistance ahead of the magnetizing inductance (that is, for frequencies of a few Hertz) current I_0 is expressed as:

$$I_0 = U / 2\pi L f$$

and the flux will be expressed as:

$$\Phi = k I_0$$

The machine torque is therefore expressed as:

$$T = K k I_0 I$$

I_0 and I are the nominal currents for which the motor is designed.

To avoid exceeding the limits, I_0 must be kept at its nominal value, which can only be achieved if the U/f ratio remains constant.

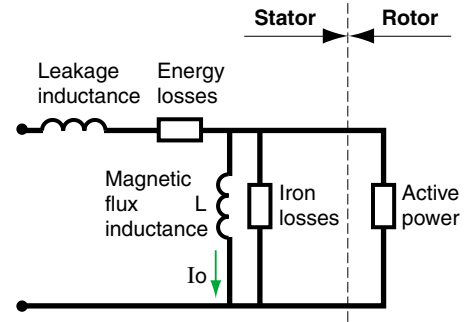

Fig. 17: Equivalent diagram of an asynchronous motor

Consequently, it is possible to obtain nominal torque and currents as long as the supply voltage U can be adjusted according to the frequency.

When this adjustment is no longer possible, the frequency can always be increased, but the current I_0 decreases and the useful torque also decreases, as it is not possible to continually exceed the nominal current of the machine without risking a temperature rise.

To achieve constant torque operation whatever the speed, the U/f ratio must be kept constant. This is what a frequency inverter does.

■ Effect on the speed

The speed of rotation of an asynchronous motor is proportional to the frequency of the supply voltage. This property is often used to make specially designed motors operate at very high speed, for example with a 400 Hz supply (grinding machines, laboratory and surgical equipment, etc). It is also possible to achieve variable speed by adjusting the frequency, for example from 6 to 50 Hz (conveyor rollers, lifting equipment, etc).

Adjusting the speed of 3-phase asynchronous motors

(subject described in detail in "Cahier Technique" no. 208)

For many years, there were very few possibilities for adjusting the speed of asynchronous motors.

Squirrel cage motors were mostly used at their nominal speed. In practice only pole-changing motors or motors with separate stator windings, which are still frequently used nowadays, could provide several fixed speeds.

Nowadays, with frequency inverters, squirrel cage motors are controlled at variable speed, and can thus be used in applications previously reserved for DC motors.

Pole-changing motors

As we have already seen, the speed of a squirrel cage motor is dependent on the frequency of the line supply and the number of pairs of poles. It is therefore possible to obtain a motor with two or more speeds by creating combinations of coils in the stator that correspond to different numbers of poles.

This type of motor only allows speed ratios of 1 to 2 (4 and 8 poles, 6 and 12 poles, etc). It has six terminals (see Fig. 18).

For one of the speeds the line supply is connected to the three corresponding terminals. For the second, the terminals are linked to one another, as the line supply is connected to the other three terminals.

More often than not, at both high and low speed, starting is carried out by connecting directly to

the line supply without using any special device (DOL starting).

In some cases, if required by the operating conditions and permitted by the motor, the starting device automatically performs the change to low speed before initiating the change to high speed or before stopping.

Depending on the currents drawn during the Low Speed -LSP- or High Speed -HSP- connections, protection may be provided by one thermal overload relay for both speeds or by two relays (one for each speed).

In general, these motors have a low efficiency and a fairly low power factor.

Motors with separate stator windings

With this type of motor, which has two electrically independent stator windings, two speeds can be obtained in any given ratio. However their electrical characteristics are often affected by the fact that the LSP windings must withstand the mechanical and electrical stresses that result from operating the motor at HSP. Thus, this type of motor operating at LSP sometimes draws a higher current than at HSP.

It is also possible to create three and four speed motors by coupling the poles to one or both of the stator windings. This solution requires additional connectors on the coils.

Δ/Y Dahlander connection (for constant torque)

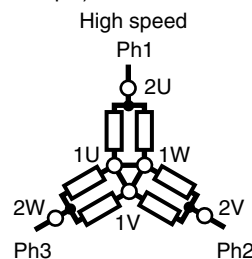
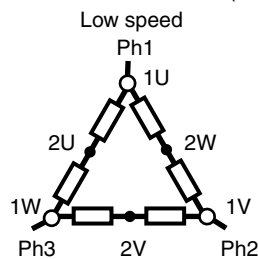

Y/Y Dahlander connection (for quadratic torque)

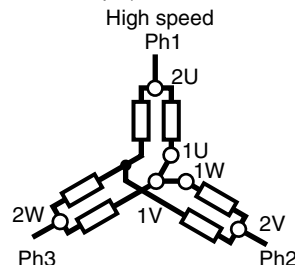
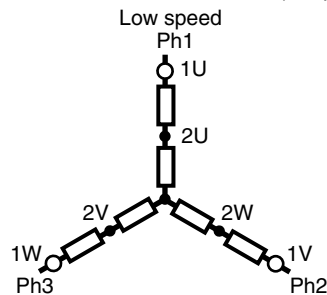

Fig. 18: Different types of Dahlander connection

3.2 Slip-ring motors

Use of the rotor resistor

The rotor resistor for this type of motor is used to define:

- Its starting torque (see section 1)
- Its speed

Connecting a permanent resistor to the rotor terminals of a slip-ring motor lowers its speed (the higher the resistance the lower the speed). This is a simple solution for varying the speed.

3.2.2. Adjusting the speed by the slip

These rotor or "slip" resistors can be short-circuited in several notches to obtain either a discontinuous adjustment of the speed, or gradual acceleration and complete starting of the motor. They must withstand the period of operation, in particular when they are intended to vary the speed. Hence, they are often quite sizeable and fairly costly.

This extremely simple process is being used less and less as it has two major disadvantages:

- During operation at low speed, a large proportion of the energy taken from the line supply is dissipated in straightforward losses in the resistors.
- The speed obtained is not independent of the load, but varies with the resistive torque applied

on the motor shaft by the machine (see Fig. 19). For a given resistance, the slip is proportional to the torque. Thus, for example, the reduction in speed obtained by a resistor can be 50% at full load and only 25% at half load, while the no-load speed remains virtually unchanged.

If an operator continuously monitors the machine, he can set the speed in a certain zone for relatively high torques by modifying the resistance value on demand, but adjustment for low torques is virtually impossible. In fact, if the operator inserts a very high resistance in order to obtain a "low speed at low torque" point, the smallest variation in the resistive torque causes the speed to increase from zero to almost 100%. The characteristic is too unstable.

For machines with special variation of the resistive torque according to the speed, adjustment can also prove impossible.

Example of slip operation:

For a machine which applies a resistive torque of 0.8 Tn to the motor, different speeds can be obtained, represented by the sign ● on the diagram in figure 19.

At steady torque, the speed decreases while the rotor resistance increases.

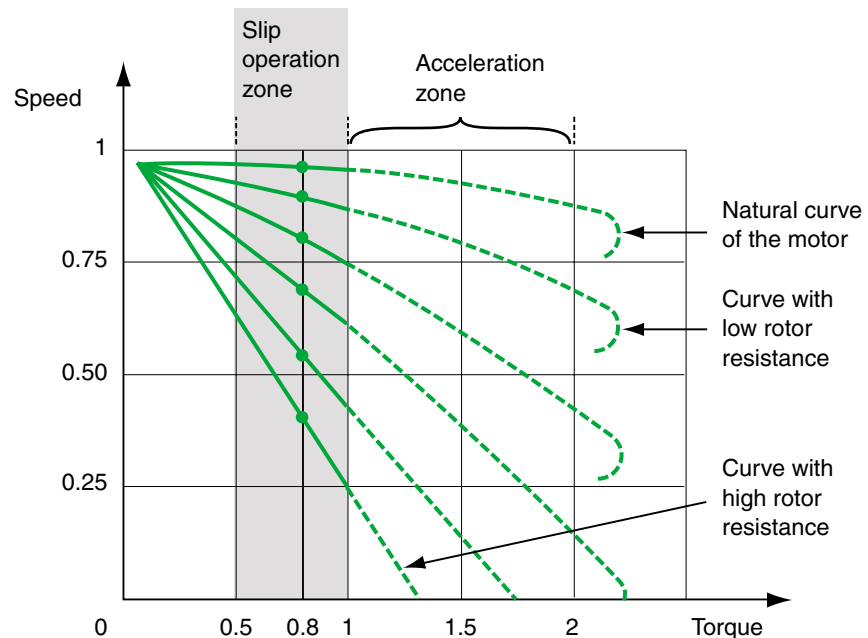

Fig. 19: Speed/torque curve with "slip" resistor

3.3 Other speed variation systems

Variable voltage regulator

This device is only used for low power asynchronous motors. It requires a resistive cage motor.

Speed variation is achieved by increasing the motor slip by reducing the voltage.

It is fairly widely used in ventilation, pump and compressor systems, applications for which its available torque characteristic provides satisfactory operation. However, as frequency inverters are now becoming very competitive, they are gradually replacing this solution.

Other electromechanical systems

The use of the electromechanical speed adjustment systems described below is on the decline since the generalization of electronic variable speed drives.

■ AC commutator motors (Schrage)

These are special motors. Speed variation is achieved by varying the position of the brushes on the commutator in relation to the neutral line.

■ Eddy current drives

This consists of a drum directly connected to the asynchronous motor operating at constant speed, and a rotor with a coil supplied with DC (see Fig. 20).

The movement is transmitted to the output shaft by electromagnetic coupling. The slip of this assembly can be adjusted by adjusting the excitation of this coil.

A built-in tachogenerator is used to control the speed with a high degree of accuracy.

A ventilation system is used to evacuate the losses due to the slip.

This principle was widely used in lifting equipment and in particular cranes. Its construction makes it a robust system with no wearing parts, which is suitable for intermittent operation and for power levels up to a hundred or so kW.

■ Ward Leonard set

This device, which was widely used in the past, consists of a motor and a DC generator which supplies a DC motor (see Fig. 21).

Speed control is achieved by regulating the excitation of the generator. A low control current enables powers of several hundred kW to be controlled in all the torque-speed quadrants. This type of drive was used on rolling mills and elevators for mining.

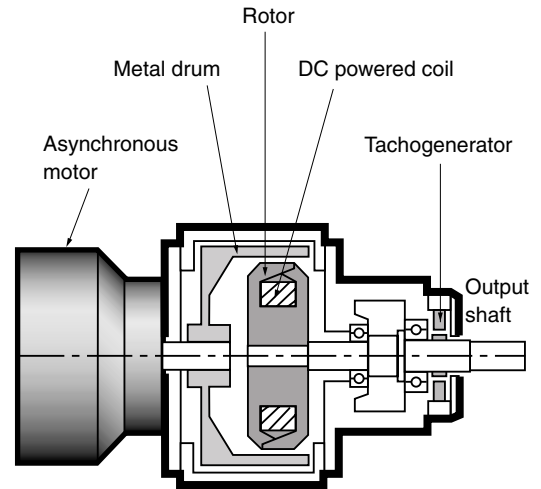

Fig. 20: Schematic cross-section of an eddy current variable speed drive

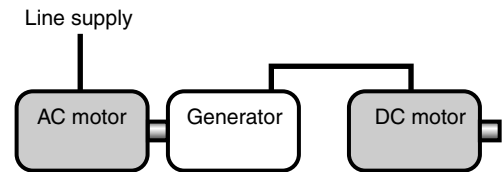

Fig. 21: Diagram of a Ward Leonard set

This variable speed control solution was the most economical and provided the highest performance levels prior to the appearance of semiconductors, which have now rendered it obsolete.

Mechanical and hydraulic speed drives

Mechanical and hydraulic drives are still used today.

Many solutions have been devised for mechanical drives (pulleys/belts, ball bearings, cones, etc). These drives have the disadvantage

of requiring meticulous maintenance and are difficult to use for servocontrol. These drives face strong competition from frequency inverters.

Hydraulic drives are still very widely used for specific applications. They are characterized by significant output powers and the ability to

develop high torques at zero speed continuously. In industry they are mainly to be found in servocontrol applications.

This type of drive will not be described here as it does not fall within the framework of this study.

4 Conclusion

The following table gives a quick overview of all the available electric motors, together with their main characteristics and the areas in which they are used.

We must stress the importance of 3-phase squirrel cage asynchronous motors. The term

"standard" applied to this type of motor is now even more appropriate since they are ideal for uses that have arisen from the development of electronic devices for variable speed control.

Type of motor	Squirrel cage asynchronous		Slip-ring asynchronous	Synchronous wound rotor	rare earth rotor	Stepper	DC
	3-phase	single phase					
Motor cost	Low	Low	High	High	High	Low	High
Dust and damp proof motor	Standard	Possible	On request, expensive	On request, expensive	Standard	Standard	Possible, very expensive
DOL starting	Easy	Easy	Special starting device	Impossible above a few kW	Not possible	Not possible	Not possible
Variable speed control	Easy	Very rare	Possible	Frequent	Always	Always	Always
Cost of variable speed control solution	Increasingly economical	Very economical	Economical	Very economical	Fairly economical	Very economical	Very economical
Speed control performance	Increasingly higher	Very low	Average	High	Very high	Medium to high	High to very high
Use	Constant or variable speed	Constant speed for the majority	Constant or variable speed	Constant or variable speed	Variable speed	Variable speed	Variable speed
Industrial use	Universal	For low power ratings	Decreasing	High power ratings at medium voltage	Machine tools, high dynamics	Open loop position control, for low powers	Decreasing

Schneider Electric

Direction Scientifique et Technique,
Service Communication Technique
F-38050 Grenoble cedex 9
Fax: 33 (0)4 76 57 98 60
E-mail : fr-tech-com@schneider-electric.com

DTP: SEDOC Meylan.
Transl.: Lloyd International - Tarporley - Cheshire - GB.
Editor: Schneider Electric
- 20 € -