

Cahier technique n° 181

Directional protection equipment

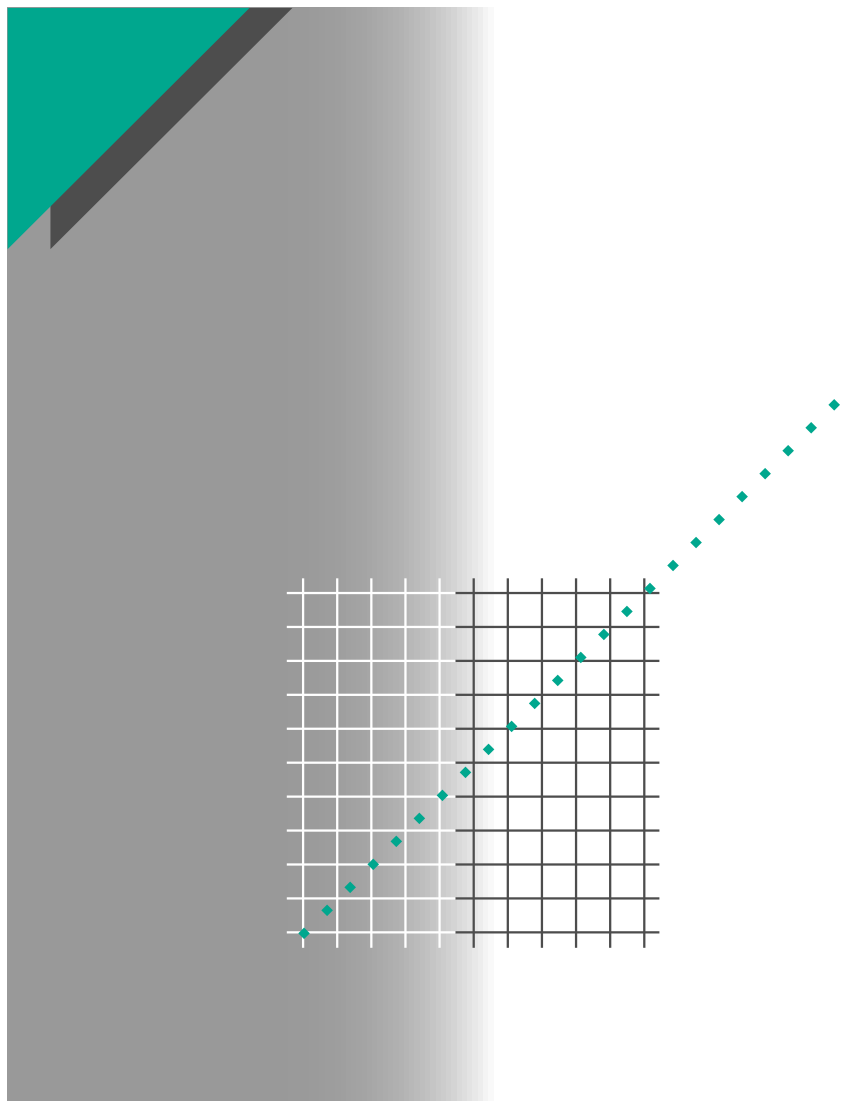

P. Bertrand



GROUPE SCHNEIDER

Cahiers Techniques are a collection of documents intended for engineers and technicians people in the industry who are looking for information in greater depth in order to complement that given in display product catalogues.

These Cahiers Techniques go beyond this stage and constitute practical training tools.
They contain data allowing to design and implement electrical equipment, industrial electronics and electrical transmission and distribution.
Each Cahier Technique provides an in-depth study of a precise subject in the fields of electrical networks, protection devices, monitoring and control and industrial automation systems.

The latest publications can be downloaded on Internet from the Schneider server.

code: **<http://www.schneiderelectric.com>**
section: **mastering electrical power**

Please contact your Schneider representative if you want either a Cahier Technique or the list of available titles.

The « Cahiers Techniques » collection is part of the Groupe Schneider's « Collection Technique ».

Foreword

The author disclaims all responsibility further to incorrect use of information or diagrams reproduced in this document, and cannot be held responsible for any errors or oversights, or for the consequences of using information and diagrams contained in this document.

Reproduction of all or part of a Cahier Technique is authorised with the prior consent of the Scientific and Technical Division. The statement « Extracted from Schneider Cahier Technique no..... (please specify) » is compulsory.

n° 181

Directional protection equipment



Pierre BERTRAND

An INPG Engineer (Institute National Polytechnique de Grenoble) graduating in 1979, he joined Merlin Gerin in 1983 and was involved in research on the operation and disturbances on electrical networks up to 1986. He then joined the Protection and Control activity in which he held various marketing and technical positions. He is currently leading an electrotechnical excellence group within this activity's technical department.

Lexicon

ANSI code: digital code assigned to a protection function, defined in the ANSI C37-2 standard.

Characteristic angle (in a directional protection equipment): angle between the polarisation quantity of relay and the normal to the tripping zone boundary line (see [fig. 10](#)).

Differential protection: zone protection which detects a fault by measuring and comparing currents at the input and output of the protected zone or equipment.

Directional protection: protection equipment capable of detecting a fault upstream or downstream (in a given direction) of its position.

Earth fault (e/f) protection: protection in which the residual variable (current and/or voltage) is monitored to detect phase-to-earth fault.

Phase protection: protection in which the phase current and/or voltage variables are monitored.

Phase-to phase-voltage (annotation):
 $U_{32} = V_2 - V_3$.

Polarisation quantity (in a directional protection equipment): the variable used as the phase reference.

Protection plan: the protection equipment incorporated in an electrical network in order to detect faults and to disconnect the smallest possible part of the faulty network.

(protection) Relay: equipment used to monitor one or more electrical variable (current or voltage), generally to detect a fault and to control the opening of a circuit breaker.

Relay connection angle (in a phase directional protection equipment): the angle between the chosen polarisation variable and the phase to earth voltage of the monitored phase qualifies the polarisation variable.

Residual: (current or voltage in a three phase network) : the vectorial sum of the values of all three phases.

Zero sequence (current or voltage, in a three phase network): 1/3 of the residual variable.

Directional protection equipment

This "Cahier Technique" aims to give the reader a better understanding of so called "directional" protection: a very useful technology for HV networks and machines.

Advances in digital technology and the integration of logical selectivity, has enabled it to make great progress in terms of reliability, simplicity of incorporation and even costs.

Its use allows to implement network configuration and selectivity system improving the dependability of power supplies.

After reviewing their operating principle, the author goes on to present their many applications and gives some useful information on their incorporation.

Contents

1. Introduction	1.1 The role of directional protection equipment	p. 4
	1.2 Applications	p. 4
	1.3 The codes and symbols of the various relay types	p. 5
2. Description of directional relays	2.1 Earth fault directional protection	p. 6
	2.2 Phase directional protection	p. 9
	2.3 Power protection	p. 11
3. Applications of directional protection equipment	3.1 Protection of radial networks	p. 12
	3.2 Protection of closed rings	p. 16
	3.3 Protection of alternators	p. 19
4. Use	4.1 Sizing of current and voltage transformers	p. 21
	4.2 Selection between two or three phase protection	p. 22
	4.3 Protecting parallel connected transformers	p. 22
5. Developments and outlook	5.1 Developments in protection equipment technology	p. 23
	5.2 Developments in sensors	p. 24
	5.3 In conclusion	p. 24

1 Introduction

1.1 The role of directional protection equipment

Protection equipment has the basic role of detecting an electrical fault and disconnecting that part of the network in which the fault occurs limiting the size of the disconnected section as far as possible.

Directional protection enables better discrimination of the faulty part of the network than with overcurrent protection.

It is necessary to use it in the following conditions:

- in a system with several sources,
- in closed loop or parallel-cabled systems,
- in isolated neutral systems for the feedback of capacitive currents,
- and to detect an abnormal direction of flow of active or reactive power (generators).

Figure 1 illustrates a situation in which both power sources would be tripped if overcurrent protections were used.

Directional current protection equipment is capable of only tripping the faulty incomer.

The direction in which the fault occurs is detected by measuring the direction of current flow, or in other words the phase displacement between the current and voltage.

1.2 Applications

Directional protection equipment is useful for all network components in which the direction of flow of power is likely to change, notably in the instance of a short circuit between phases or of an earthing fault (single phase fault).

■ «phase» directional protection is installed to protect two connections operated in parallel, a loop or a network component connected to two power sources (see **fig 2**).

■ «earth fault» (e/f) directional protection is sensitive to the direction of flow of the current to earth. It is necessary to install this type of protection equipment whenever the phase to earth fault current is divided between several earthing systems.

However, this current flow is not only due to the earthing of the network's neutral, but also due to the phase to earth capacitance of the lines and cables (1 km of 20 kV cable causes a capacitive current flow of around 3 to 4 amps).

Residual directional overcurrent protection, as well as zero sequence active power protection

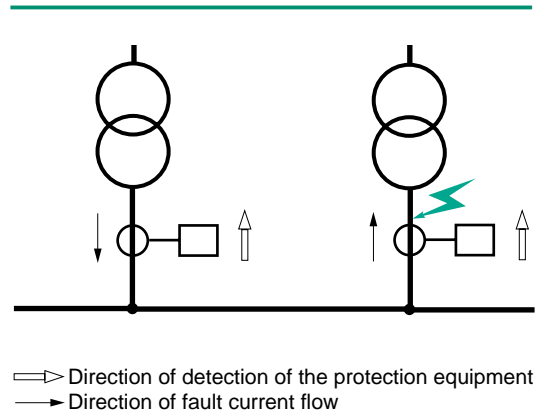

fig. 1: Illustration of an application of directional protection equipment.

Power protection equipment measures either the active or the reactive power flowing through the connection in which the current sensors are placed. The protection equipment operates if the power is greater than a set threshold **and if it is flowing in a given direction.**

Directional power and current protection requires the current and the voltage to be measured.

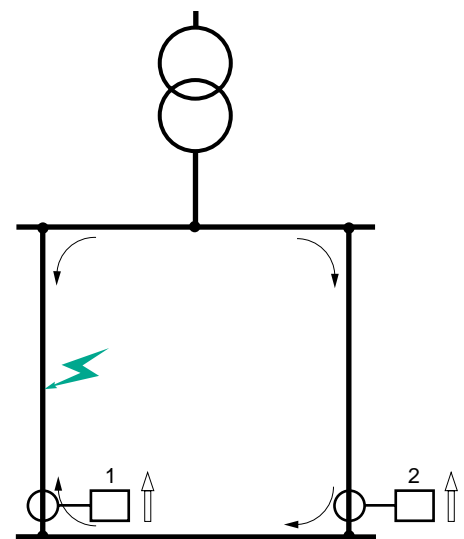

fig. 2: The directional protection equipment (1) is tripped since the direction of current flow is abnormal.

are used to protect feeders with a capacitive current of the same order of magnitude as the earthing fault current.

On these feeders, the phase to earth capacitance is sufficiently high for a zero sequence current to be detected by a non-directional e/f protection as soon as a phase to earth short circuit occurs, wherever it may be on the network (see **fig. 3**).

Directional protection is therefore complementary to overcurrent protection, enabling good discrimination of the faulty network section to be achieved in the above mentioned situations.

Active or reactive power protection equipment is used to detect abnormal power flow other than the one due to a short circuit; e.g.: in the event of the failure of the prime mover, a generator will continue to run as a synchronous motor, drawing power from the system.

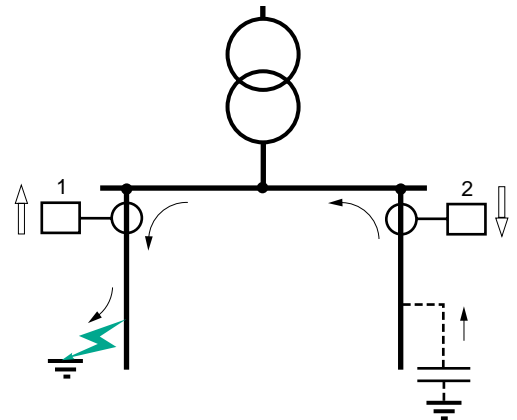

fig. 3: The directional residual current protection equipment (2) does not trip since the current is flowing in the opposite direction.

1.3 Codes and symbols of the various relay types

For each of the ANSI codes, the table in **figure 4** equipment and also gives the usual names and fields of application.

Graphical symbol	ANSI code (C37-2)	Usual names	Applicational fields
$I > \leftarrow$	67	<ul style="list-style-type: none"> ■ directional overcurrent, ■ phase directional 	directional detection of short circuits between phases
$I_r > \leftarrow$	67 N	<ul style="list-style-type: none"> ■ directional residual overcurrent ■ directional earth fault ■ zero sequence active power 	directional detection of phase to earth faults
$P >$	32 P	<ul style="list-style-type: none"> ■ active overpower ■ active reverse power 	protection of generators and synchronous motors or detection of abnormal power flow
$Q >$	32 Q	<ul style="list-style-type: none"> ■ reactive overpower ■ reactive reverse power 	
$P <$	32 P	<ul style="list-style-type: none"> ■ active underpower 	
$Q <$	32 Q	<ul style="list-style-type: none"> ■ reactive underpower 	

fig. 4: ANSI codes, symbols and applications.

2 Description of directional relays

In order to measure a value of power or to localise a fault upstream or downstream of the point at which the current is measured, the phase displacement of the current must be determined relative to a reference variable: the

phase to phase voltage for directional phase protection and the residual voltage for directional earthing protection.

This reference variable is called the polarisation quantity.

2.1 Earth fault directional protection

Input variables

In earth fault directional protection, the residual current is measured and the residual voltage is most often used as the polarisation quantity.

The latter should not be confused with the zero sequence voltage.

Recall that in any three phase system $F1$, $F2$, $F3$, symmetrical component

theory defines the **zero sequence** variable F_h as:

$$\vec{F}_h = \frac{1}{3} (\vec{F}_1 + \vec{F}_2 + \vec{F}_3)$$

The **residual** variable:

$F_r = \vec{F}_1 + \vec{F}_2 + \vec{F}_3$ is three times greater than the zero sequence variable.

■ The **residual** current is either measured by three current transformers, one per phase, or by a coil (ring CT) around the three phases.

□ The use of three current transformers (see [fig. 5](#)) has certain advantages:

- CT's are generally dependable,
- it is possible to measure high currents.

But it also has certain disadvantages:

- saturation of the CT's in the instance of a short circuit or when a transformer is switched on produces a false residual current
- in practice, the threshold cannot be set to under 10% of the CT's rated current.

□ Measuring using a ring CT (see [fig. 6](#))

- has the advantage of being very sensitive,
- and the disadvantage of the coil (low voltage insulated) being installed around a non-clad cable to insulate it.

■ Residual voltage is measured by three voltage transformers (VT); often VT's with two secondary windings are used (see [fig. 7](#)): one is star connected and enables both phase to neutral and phase to phase voltages to be measured; the other is open delta connected enabling the residual voltage to be measured.

If the main VT's only have one secondary winding are star connected, and grounded, a set of auxiliary VT's can be used to measure the residual voltage (see [fig 8](#)). This situation is often encountered when the protection plan for existing installations is upgraded.

It should be noted that certain protection equipment does not require auxiliary VT's, the equipment itself providing the residual voltage value from the three phase to earth voltages.

■ The residual voltage is most often used as the polarisation variable for an earth fault directional relay; however, it may also be taken as the current in the installation's neutral earthing arrangement (see [fig. 9](#)).

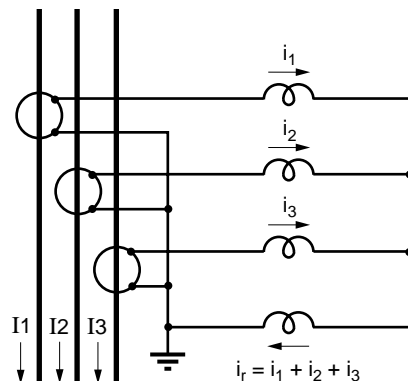

[fig. 5](#): Measuring the residual current using 3 CT's.

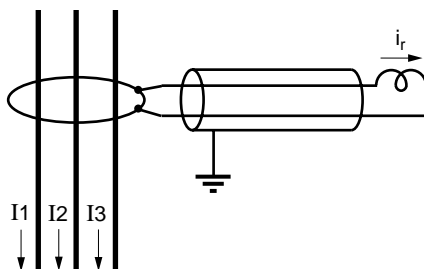

[fig. 6](#): Measuring the residual current using 3 CT's.

In theory, both these ways of polarising the protection equipment are equivalent. If Z_h is the transformer's zero sequence impedance and Z_n the impedance of the neutral point, the residual voltage, V_r , and the current of the neutral point, I_n , are related by the following equation (written in complex numbers!): $V_r = (Z_h + 3Z_n) I_n$.

In practice, polarisation by the neutral point current is only used in networks with an earthing

fault current that is both large (several hundreds of Amps) and at the same time much greater than the current due to parasite capacitance on the network.

In this instance the current measurement is more accurate than that of residual voltage, which has a very small value. It can only be used in substations that are near to the neutral earthing connection.

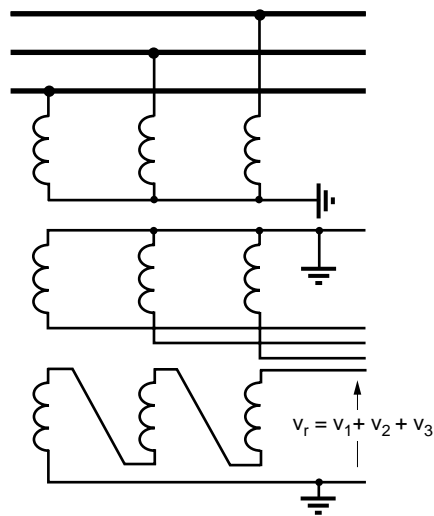

fig. 7: Measuring the residual current using 3 CT's.

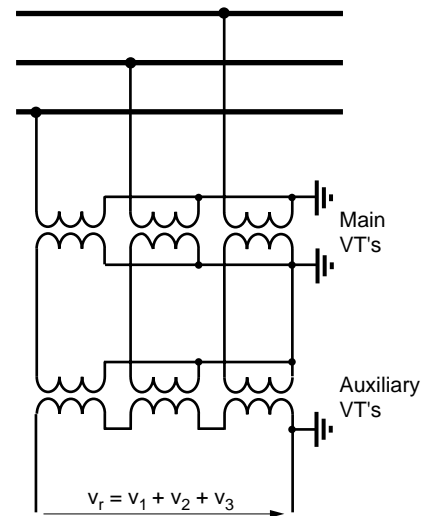

fig. 8: Measuring the residual voltage using auxiliary VT's.

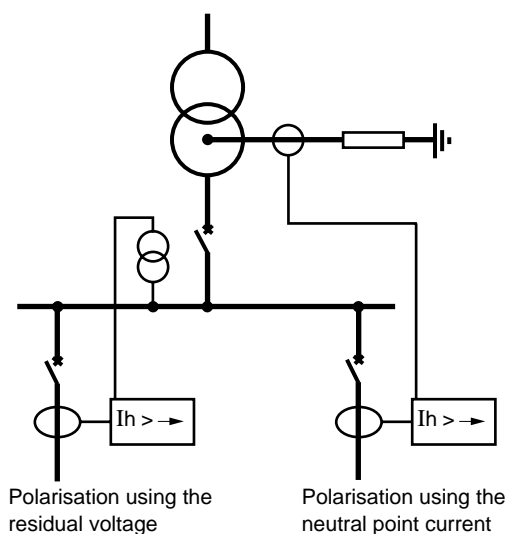

fig. 9: The two polarisation modes in directional earthing protection.

Characteristic angle

To determine the direction of the fault, the protection equipment measures the phase displacement between the current and the polarisation variable. If the polarisation variable is not in the axis of symmetry of the wished relay's action (the characteristic axis, see **fig 10**), it is necessary to re-phase it; this is done by adjusting the characteristic angle.

When designing the protection coordination, the characteristic angle of directional protection equipment must be determined so that any fault in the chosen direction causes a current that falls in the tripping zone and that any current in the other direction causes a current falling outside of this zone.

The characteristic angle depends on the chosen polarisation variable and on the network's neutral point arrangement (for residual current directional protection equipment).

Therefore, the characteristic angle is often adjustable. The main applications and the corresponding settings are looked at in chapter 3.

To be able to measure the phase displacement between the current and the polarisation variable, it is essential for the latter to be sufficiently large (generally ≥ 0.5 to 2% of the rated value of the variable). If the polarisation variable is less than this threshold then the protection equipment does not operate, whatever the measured current value.

Principles of detection

Three principles of detection exist concurrently; they correspond to various requirements and sometimes to various practices:

- directionalized overcurrent,
- measurement of the projection of the current,

- measurement of the residual active power.

The first two are used for phase and earth fault detection, the last one is specific to earth fault detection with a special neutral point arrangement.

■ Directionalized overcurrent (see **fig. 10**)

This type of directional relay is made by combining overcurrent protection equipment with an equipment to measure the phase displacement between the current and the polarisation variable.

Tripping is subject to the two following conditions:

- the current is greater than the threshold, and
- the phase displacement between the current and the polarisation variable, defined by the characteristic angle, is in the zone between $+90^\circ$ and -90° .

■ Measurement of the projection of the current (see **fig. 11**)

This type of protection equipment calculates the projection of the current along the characteristic axis. The value obtained is then compared with a threshold in order to determine whether or not to trip.

■ Measurement of the residual active power

This type of protection equipment actually measures the residual active power and the threshold is expressed in Watts. It must be designed to avoid any spurious tripping caused by measurement inaccuracy in the instance of a strong capacitive residual current (strong residual reactive power); the operating zone is limited as shown in **figure 12**.

To detect earthing faults, the most universal principle is that of measuring the projection of the current.

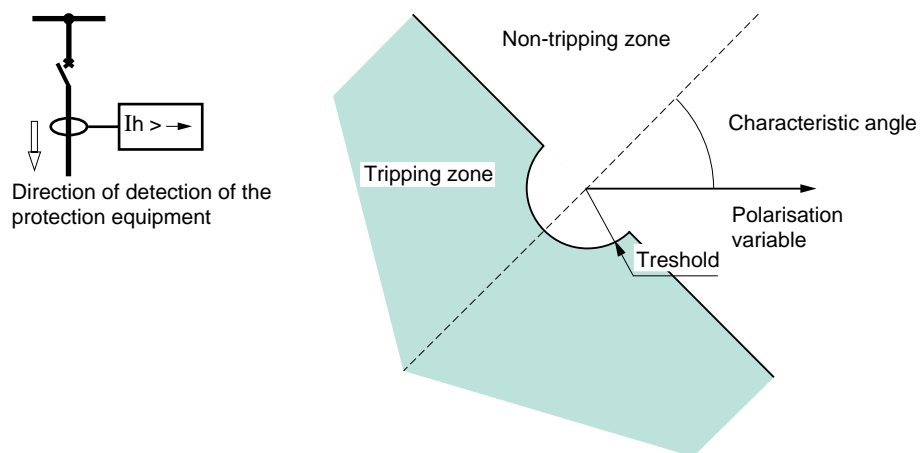

fig. 10: Operating characteristics of earth fault directional overcurrent protection equipment.

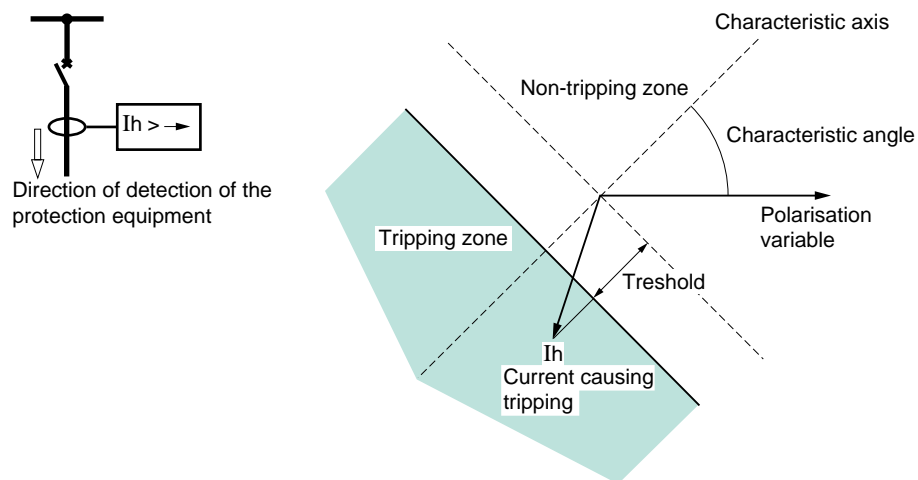

fig. 11: The two polarisation modes in directional earthing protection.

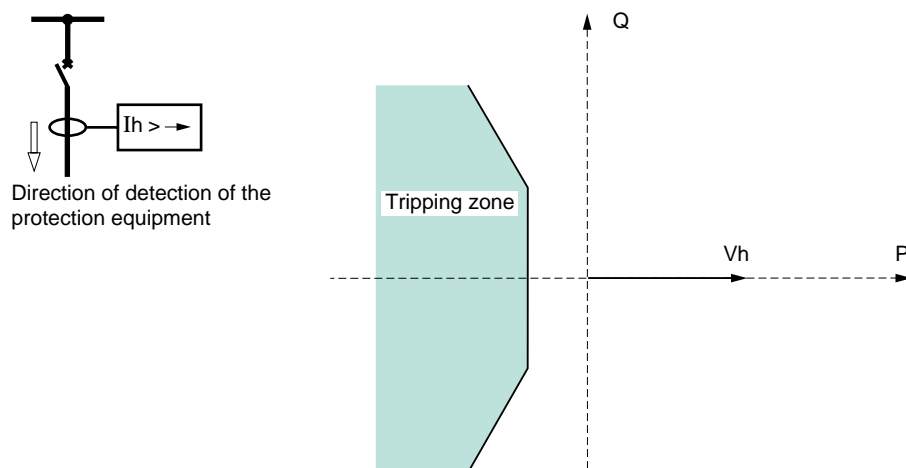

fig. 12: Operating characteristics of protection equipment measuring the zero sequence active power.

The use of directionalized overcurrent relays is not suited to all neutral point arrangements (chapter 3 shows that this principle cannot be used with compensated neutral point arrangements).

Protection equipment measuring the residual active power is restricted to use with compensated neutral point arrangements in competition with current projection type relays.

2.2 Phase directional protection

Angle of connection, characteristic angle

■ more often than not, this type of protection equipment is two phase comprising two independent, single phase elements. Sometimes three-phase protection equipment must be used (see § 4).

For each monitored phase, the relay measures its current magnitude, and then uses a phase to phase voltage as the polarisation variable. The phase to neutral voltage is not used since it varies greatly when a fault occurs to earth, due

to the displacement effect of the neutral point (residual voltage).

■ When the relay measures the current in phase 1, the polarisation voltage most often used is V_2-V_3 . The protection equipment's angle of connection is then said to be 90° (see **fig. 13**).

■ Similarly to a directional earthing relay, the characteristic angle of a directional phase relay defines the position of the angular tripping zone. It is the angle between the normal to the tripping plane and the polarisation variable.

■ In order to be able to measure the fault direction, the polarisation variable (the voltage) must have a sufficiently high value. In particular, a three-phase fault very close to a directional relay is not detected because all of the phase to phase voltages are zero.

To obtain the direction of this type of fault, the protection system must use a memory voltage.

Principles of detection

Phase directional relays function either as directionalized (see **fig. 14**) overcurrent element, or by measuring the projection of the current on the characteristic axis.

Although relays functioning on both principles exist on the market, the directional overcurrent relay should be preferred.

Co-ordinating overcurrent protection equipment is much easier since the detection threshold is independent of the current's phase.

The power measurement is not used to detect short circuits. Power is not a good fault detection criteria because in the instance of a fault between phases the nearer the fault is the lower its value.

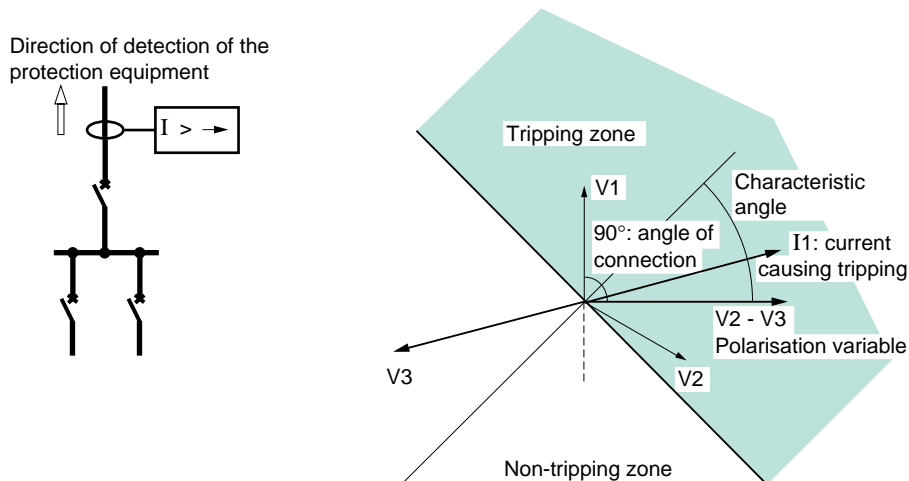

fig. 13: A relay measuring the current I_1 and the voltage V_2-V_3 has a 90° relay connection.

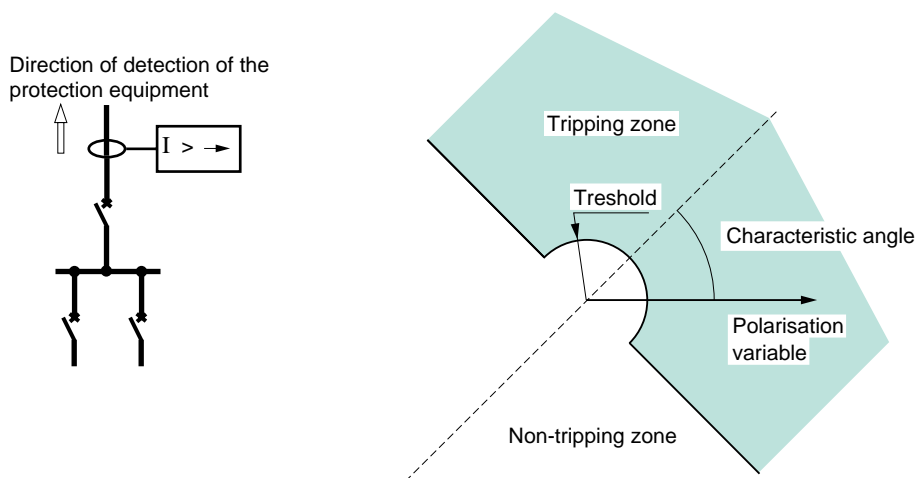

fig. 14: Operating characteristics of directional overcurrent protection equipment.

2.3 Power relays

This type of protection equipment often uses a dual wattmeter method to measure the active power, with a variant, that we will call the dual VARmeter method, which measures the reactive power.

Recall that this method enables the power to be measured using two current and two phase to phase voltage measurements (see [fig. 15](#)). It applies to a three-phase network, whether balanced or not, **as long as there is no zero sequence current in the circuit.**

This method is particularly unsuited to low voltage 4-wire networks, or in other words a network in which the neutral is distributed, supplying single phase loads connected between the phase and the neutral.

The active power is given by:

$$P = I_1 U_{31} \cos (I_1, U_{31}) + I_2 U_{32} \cos (I_2, U_{32}).$$

Similarly, the reactive power is given by:

$$Q = I_1 U_{31} \sin (I_1, U_{31}) + I_2 U_{32} \sin (I_2, U_{32}).$$

The measured power is therefore an algebraic variable, and the direction of flow is indicated by its sign (+/-). Power protection equipment is therefore naturally directional. Certain relays use

three single phase measurements to determine the power.

These relays will therefore be usable with 4-wire networks ; they do however have the disadvantage of requiring 3 VT's and 3 CT's to be installed.

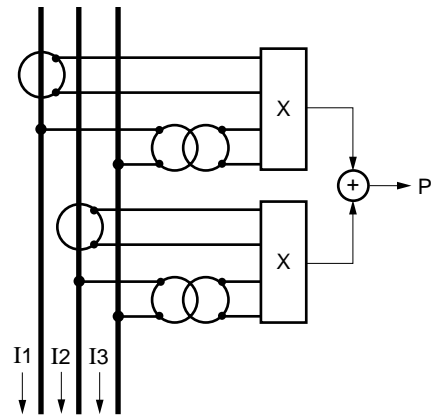

fig. 15: Layout diagram for measuring power.

3 Applications of directional protection equipment

3.1 Protection of radial networks

A few reminders

■ Capacitive current

Any live part forms a capacitor relative to earth (see **fig. 16**). This is particularly true for cables, for which the capacitance per kilometer is commonly of the order of several microfarads ; it is also true for lines, but with a capacitance of approximately 100 times lower in value.

The capacitive effect of cables is such that supplying power to 50 km of cable under no-load conditions at 20 kV, is the equivalent to connecting 3 MVAR of capacitors between the network and the earth!

As long as the cable is supplied from a balanced three-phase voltage, the sum of the capacitive currents of the three phases is almost zero. However, when there is a phase to earth fault in the network, one of the phase to earth voltages is lower than the others. The capacitive currents are no longer balanced and a residual capacitive current is observed. The flow of currents is diagrammatically represented in **figure 17**.

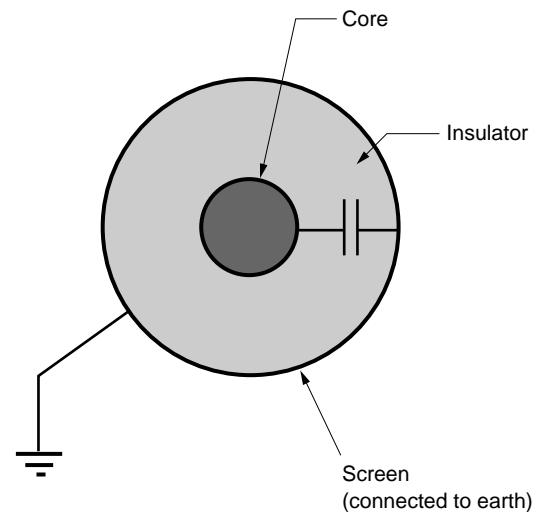

fig. 16: An electric cable behaves as a capacitor.

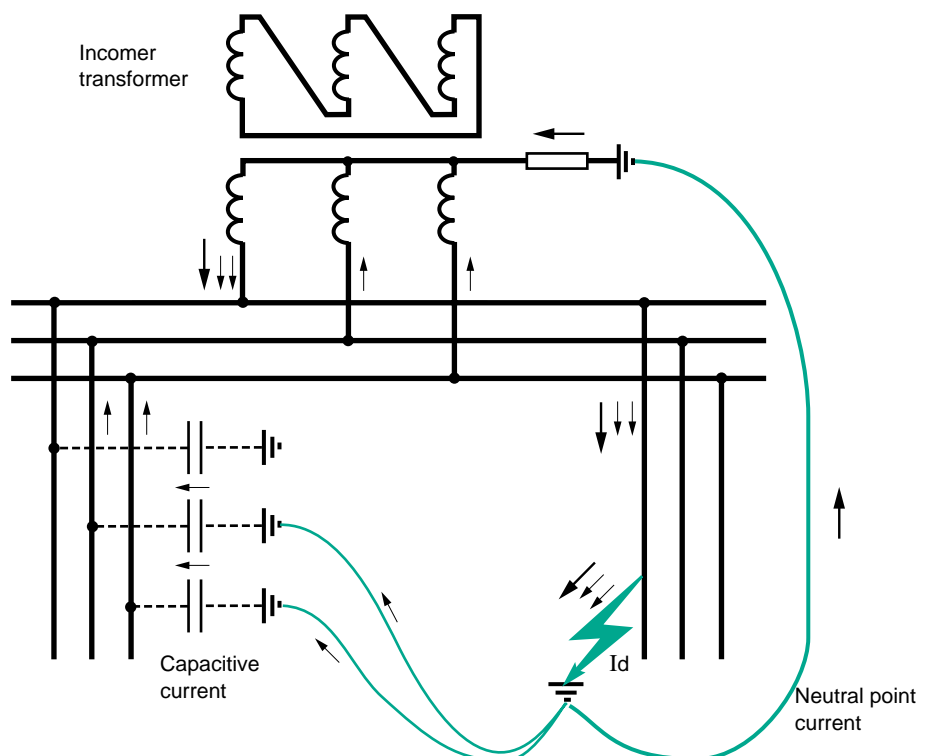

fig. 17: Circulation of capacitive currents during a phase to earth fault.

In order to incorporate protection equipment, it is **necessary** to calculate, for a given feeder, the maximum value of the residual capacitive current. This is the current that would be measured by a coil placed on this feeder when one phase is earthed upstream of it whilst the two others are at the network's rated phase to phase voltage.

It is generally called the feeder's capacitive current.

The value of this current is :

$$I_c = 3 C \omega V$$

in which :

- C is the capacitance of each phase relative to the earth
- V is the phase to neutral voltage
- ω is the angular frequency ($2 \pi f$).

■ The neutral point arrangement

The choice of the neutral earthing connection arrangement is an important stage in designing an electrical network. It is always a result of a compromise between several factors.

A factor that is frequently favoured is the desire to reduce the fault current in order to improve the human safety (by limiting the increase in potential of the fault earthing points), and of equipment (by limiting the energy released through electrical short circuit arcing). We will see that by limiting the fault current we make it more difficult to detect the fault and consequently it becomes essential to use an earth fault directional protection system. If the fault current is sufficiently weak, we no longer need to instantly cut off the supply, and this in turn enables a considerable improvement to be achieved in continuity of service.

During a fault, the capacitive current superposes itself on the current limited by the neutral earthing impedance.

Consequently, in networks with large capacitive currents, the only way of obtaining a low fault

current is to choose an inductive earthing impedance whose current compensates for the capacitive current. When this neutral point inductance is constantly adjusted to retain this balance ($3 L C \omega^2 = 1$), it is called a Petersen coil ; in this case the fault current is theoretically zero.

Earthing fault protection

Directional earthing protections are used on radial networks in two situations:

- when a feeder's capacitive current is of the same order of magnitude as the protection equipment's threshold current (which must be quite low in order to detect resistive faults),
 - when the neutral is earthed in several places.
- Networks with long feeders

When a feeder has a high capacitive current - normally one greater than 10 % of the current limited by the neutral earthing impedance - a simple residual overcurrent relay is no longer enough to give sensitive and selective protection.

If its threshold is set to a value below the capacitive current of the protected feeder, it will be subject to spurious tripping for all phase to earth faults on the network.

In this case, a satisfactory protection system for the feeder will consist of a directional earthing relay whose threshold can be set to below the capacitive current.

The characteristic angle will be set according to the neutral point arrangement of the installation;

- Isolated neutral network:

Operation

- The general protection of the network is performed by a continuous insulation level monitor or by residual overvoltage protection equipment (displacement of the neutral point),
- Directional earthing protection equipment detects the faulty feeder,
- The characteristic angle is chosen: $\theta = 90^\circ$ (see **fig. 18**).

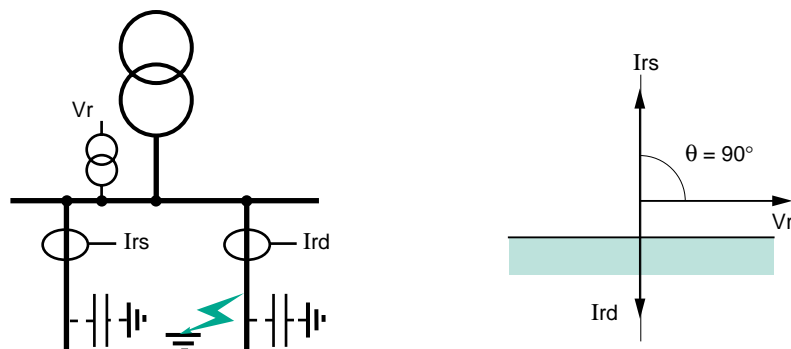

fig. 18: Isolated neutral network: detection of the earthing faults.

Comment

This only operates if the capacitive current is sufficiently high. In practice the minimum value is: 1A.

□ Resistance earthed neutral network (see **fig 19**):

In the faulty feeder, the neutral point current, which is active, is added to the capacitive current in the non-faulty feeders. If the resistance of the neutral point is chosen such that the active current is greater than twice the installation's capacitive current, directional protection is not necessary.

The following characteristic angle is chosen:

- A: $\theta = 0^\circ$ for current projection type relays (set in this way, the relay is sensitive to the active residual current and insensitive to the capacitive current),

- B: $\theta = 45^\circ$, for directionalized overcurrent relays.

It should be noted that with a characteristic angle of 45° , the residual current in the non-faulty feeder is clearly in the protection system's

non-tripping zone, and therefore all principles of protection are appropriate.

With a characteristic angle of 0° , the residual current of the non-faulty feeder is at the border of the tripping zone ; it is therefore essential to use a current projection type relay. This solution then offers the advantages of being totally insensitive to the capacitive current.

□ Compensated neutral network (see **fig. 20**):

Operation

- The current in the faulty feeder arises from the superposing of:

- . the capacitive currents in the non-faulty feeders,
- . the current in the coil that compensates for the total capacitive current in the network,
- . the current in the neutral point resistance, generally less than 10% of the current in the coil (there exists networks in which this neutral point resistance is not installed however this possibility is not examined here).

- The characteristic angle is chosen as: $\theta = 0^\circ$.

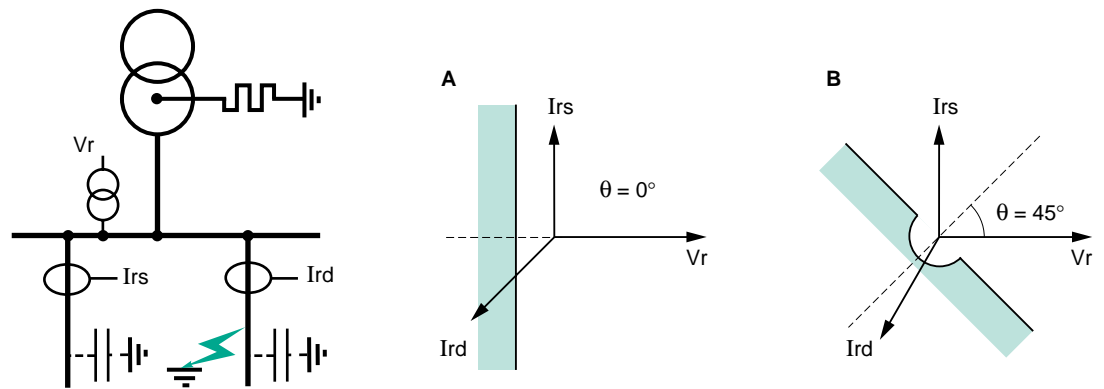
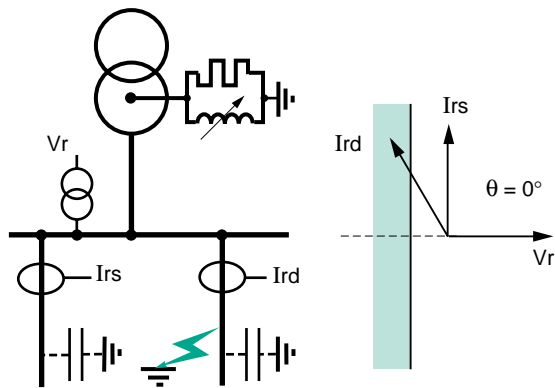

fig. 19: Resistance earthed neutral network: detection of earthing faults.

A - Permanent earthing fault



B - Recurrent fault: voltage of the faulty phase and residual current

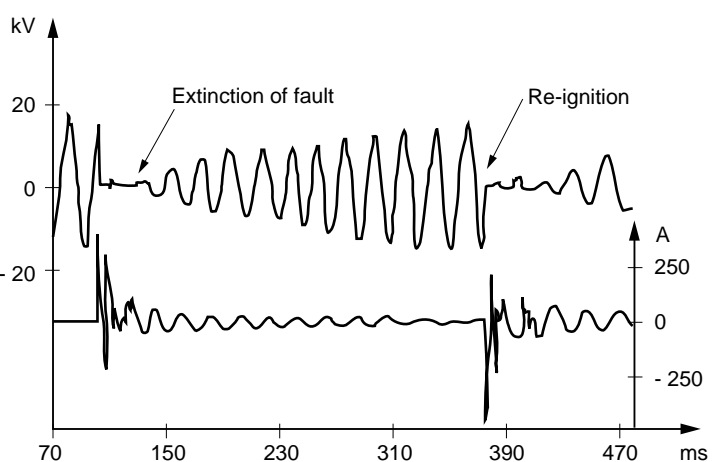

fig. 20: Compensated neutral network: detection of earthing faults.

Comment

It is essential to use current projection type protection equipment ; directional overcurrent protection equipment risks causing spurious tripping.

On this type of network, insulation faults are often recurrent in nature : the fault arc will be extinguished after several milliseconds and re-ignite several periods later as part b of **figure 20** shows. Protection equipment must be specially designed to function in the presence of this type of fault.

□ Directly earthed neutral networks (see **fig. 21**) :

Operation

- The neutral point current is mainly inductive. It is much greater than the network's capacitive current,
- The characteristic angle is chosen to be: $\theta = -45$ to -90° .

It should be noted that a simple zero sequence overcurrent relay is sufficient to detect a faulty feeder provided its threshold is set to a value that is greater than the capacitive current of the protected feeder.

Directional relays are only used in a meshed network or in one having several neutral points.

■ Multiple earthing points

Certain networks can be operated with the neutral earthed in several places. This is notably the case when the neutral is earthed in each energy source (generator unit or incomer transformer). The parallel connection of sources therefore leads to the parallel connection of the neutral earthing connections.

In this case, the selective protection of sources against earthing faults requires directional earthing protection equipment on the incomer of each of the sources.

Figure 22 shows the typical arrangement of earthing fault protection equipment.

The arrow indicates the direction of fault detection in each directional earthing protection equipment. The time delays on each piece of equipment are also shown.

The characteristic angles are chosen according to the neutral point arrangement : that of the protection equipment located on the generator set incomer according to the neutral earthing arrangement of the transformer and that of the protection equipment installed on the transformer incomer according to the neutral earthing arrangement of the alternator.

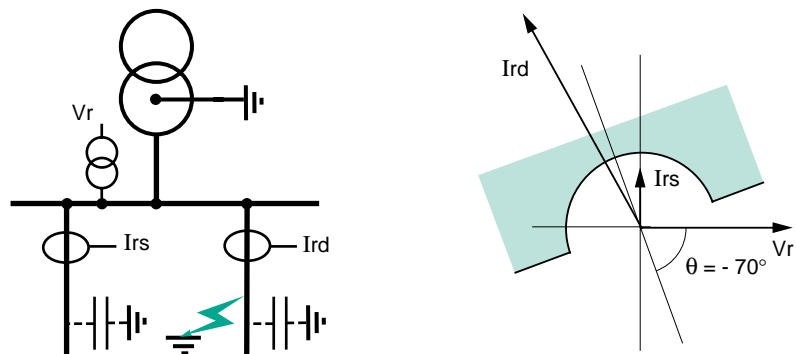

fig. 21: Directly earthed neutral network: detection of earthing faults.

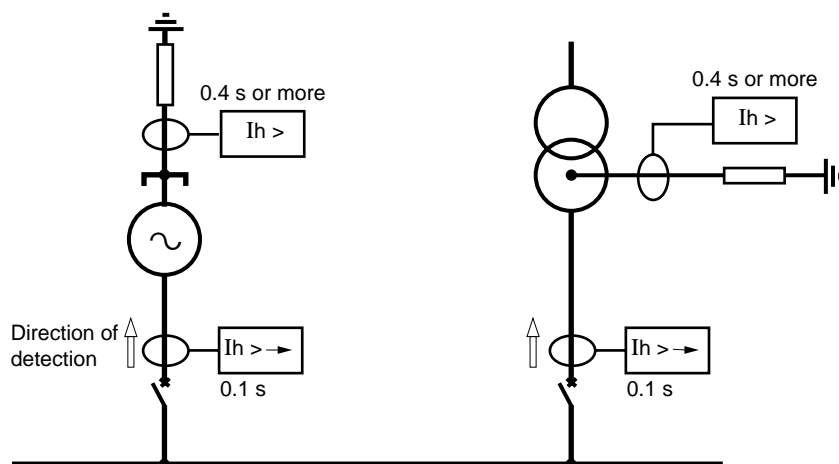

fig. 22: Earthing fault protection on a network earthed at several points.

Phase to phase fault protection

Directional phase protection equipment is used on a radial network for substations supplied simultaneously by several sources.

In order to obtain good continuity of service, it is important that a fault affecting one of the sources does not cause all the sources to trip. The required selectivity is achieved by installing phase directional protection equipment on the incomer of each of the sources.

Figure 23 shows a typical layout for phase to phase fault protection equipment. In this figure, the arrow shows the direction of detection of each directional phase protection equipment.

Directional phase protection equipment is generally two phase. Cases requiring three phase protection are described in § 4.

The time delays of the protection equipment are shown. The characteristic angles are set to take account of the chosen angle of connection. For an angle of connection of 90°, the most universally used setting of the characteristic angle is 45°.

It should be noted that if the generator set's short circuit power is low compared with that of the network, the directional protection equipment installed on the generator set's incomer can be replaced by simple overcurrent protection equipment with a threshold set to be both greater than the generator set's short circuit current and less than that of the network.

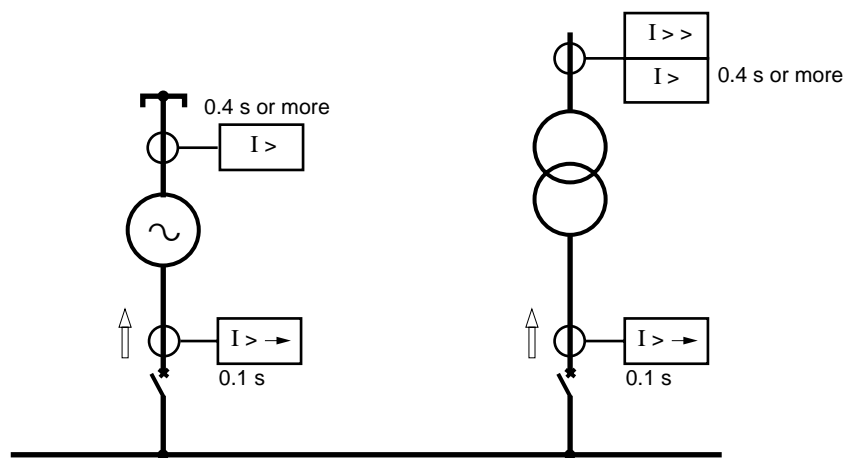

fig. 23: Short circuit protection on a network with several sources.

3.2 Protection of closed rings

■ In such networks, one or more rings are closed when in normal operation (see fig. 24). The advantage of such a network structure is that it ensures excellent dependability of power to all consumers situated on the ring ; it enables a faulty connection to be disconnected from the network without interrupting the supply to the consumers.

The disadvantage of this solution is its cost: it requires a circuit breaker to be installed at the end of each connection in addition to complex protection equipment.

- Two protection principles may be used
- differential protection
- directional protection

The latter functions if, on the ring, a single substation has one or more sources and also earths the neutral. In practice, the selectivity of directional protection equipment is ensured by logical selectivity systems.

Compared with differential protection, which has the advantage of being quick, directional

protection is less costly and easier to incorporate. Note that the detection of earthing faults is performed whatever the neutral point arrangement of the installation, whereas differential line protection equipment has limited sensitivity.

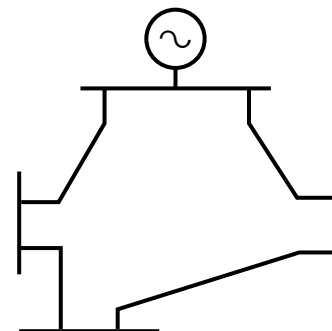

fig. 24: Closed ring layout diagram.

Parallel connected lines

Two parallel connected lines are the simplest and most frequently encountered example of a closed ring. The protection system must be designed in such a way that a fault on one line does not cause the other line to trip.

A typical protection system is shown in **figure 25**. In this figure, the arrow shows the direction of detection of each directional protection equipment.

Directional phase protection equipment is of two phase type. Its characteristic angle is set to take account of the chosen angle of connection (45° for an angle of connection of 90°).

The characteristic angle of directional earthing protection equipment is set according to the neutral point arrangement as explained in the previous paragraphs.

The protection equipment time delays are shown in the figure. Non directional protection equipment used on upstream substation feeders are time delayed so as to grade with the directional protection equipment of the downstream substation incomers.

In the instance of a short circuit on one of the lines, the current is divided according to the impedance in each circuit : part flows directly

from the upstream substation in the faulty line, the rest passes through the downstream substation.

The protection equipment is activated in the following order :

- A1, D1 and D2 detect the fault,
- A1 trips (time delay : 0.1 s),
- D2 resets before its time delay has elapsed,
- D1 trips (time delay : 0.4 s).

When a short circuit occurs near to the upstream substation's busbars, the proportion of current passing through the downstream substation is very low, less than the directional phase protection threshold value.

This is the case when the position «x» of the fault is between 0 and twice the ratio of I_s/I_{sc} (between the directional protection relay's threshold and the short circuit current). In this case, the faulty line feeder's overcurrent protection equipment (D1) trips first (time delay: 0.4 s) with A1 tripping next.

The total time to elimination of the fault is therefore prolonged. This disadvantage can be overcome by installing a second overcurrent relay on feeders D1 and D2 with a high threshold (tripping for a I_{sc} corresponding to less than 90% of the length of the line) with a time delay of 0.1 s.

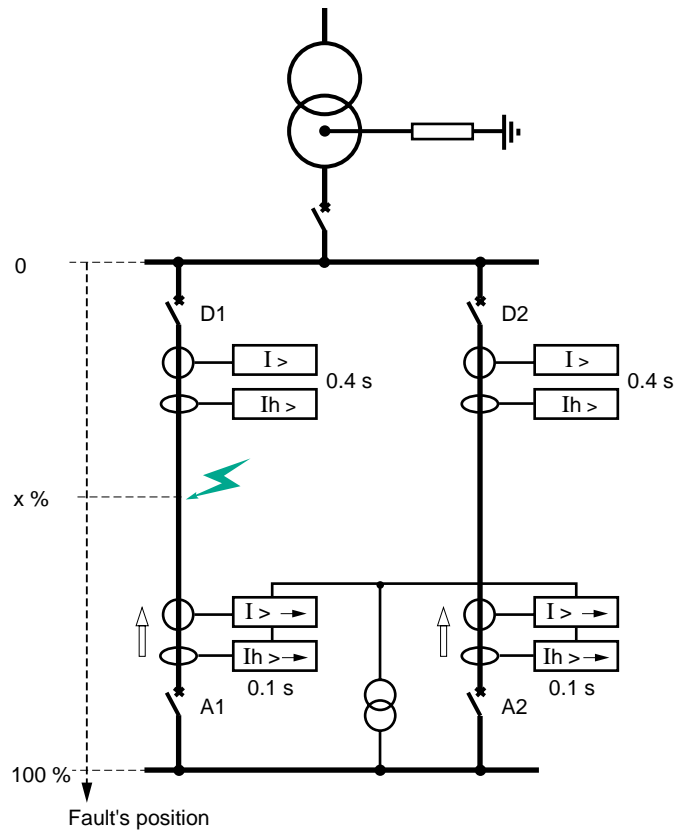

fig. 25: Protection of parallel connected lines.

Closed loop

Each circuit breaker is equipped with two directional protection systems, each detecting the fault in opposite directions (apart from the circuit breakers at the start of the loop, which are equipped with a single non-directional type protection system). This protection equipment arrangement is shown in **figure 26**. Each protection system comprises two phase directional protections and two earth fault directional protection equipments. The direction of detection of each protection system

is shown by an arrow. Two selectivity series are formulated, one for each direction that the fault current can flow in :

- $A > B > C > D > E$,
- $F > E > D > C > B$.

If the selectivity is purely time-based, the tripping times rapidly become prohibitive. In practice, this solution is implemented with logical selectivity (see **fig. 27**), which enables very short tripping times (0.1 s) to be obtained by using line links between each substation.

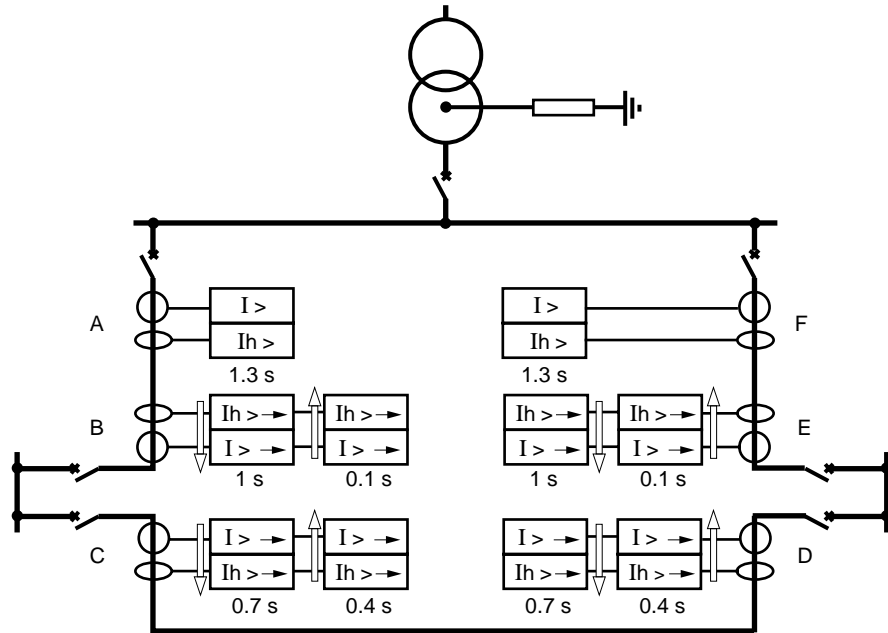

fig. 26: Protection of a closed loop using directional relays and time-based selectivity.

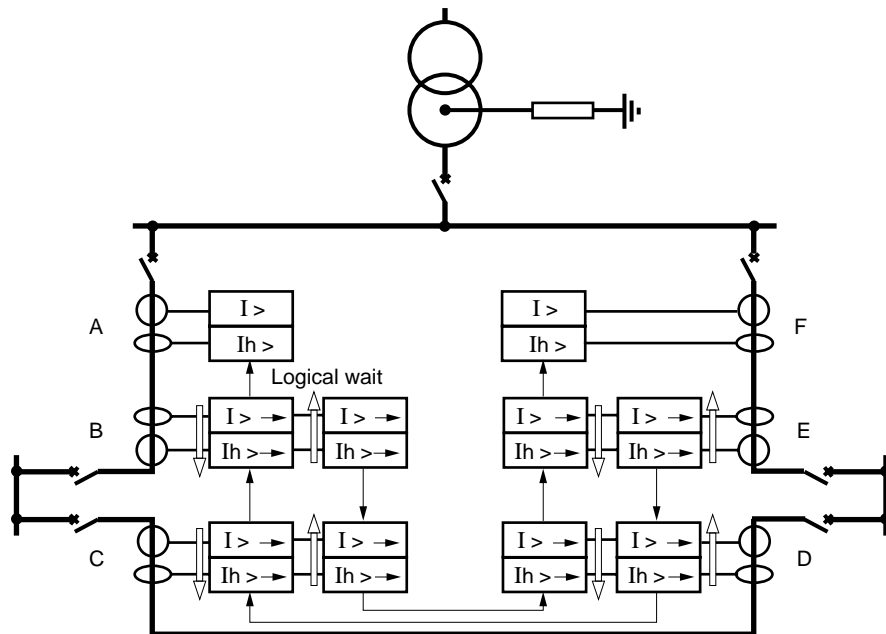

fig. 27: Protection of a closed loop by directional relays and logical selectivity.

3.3 Protection of alternators

Detection of the loss of excitation

The break or the short circuiting of the excitation coil of an alternator is a serious fault. It either causes the alternator to function as an asynchronous generator, or it stops the conversion of energy and causes an increase in speed. The first case occurs if the excitation circuit is short circuited or if the rotor has damper windings; the situation is stable, but the machine is not designed to accept it for very long. In the second case, the situation is unstable and the drive machine must be stopped as quickly as possible.

It is therefore necessary to monitor the excitation circuit. Unfortunately, it is often inaccessible, located totally within the rotor (alternator without rings or brushes). We then use the measurement of the reactive power absorbed by the machine or the measurement of the impedance at its terminals (see [fig. 28](#)).

The reactive power measurement is most often used to protect low and medium power machines. It detects any absorption of reactive power and therefore any time the alternator is functioning as an asynchronous generator. It must be possible to set the threshold to a value

lower than S_n (the machine's rated apparent power) ; typically $0.4 S_n$.

Detection of motor operation

A generator set connected to a power network continues to turn synchronously even if the prime mover (diesel or turbine) is no longer energy supplied. The alternator then functions as a synchronous motor. Operating in such a way may be detrimental to the prime mover.

In order to detect such operation, a directional active power relay must be used (see [fig. 29](#)). The threshold of this protection equipment is set to a low value compared with the alternator's rated apparent power, typically between 5 and 20%, sometimes less for turbo-alternators. Special attention must be given to the design of this very sensitive relay in order to ensure stability under all normal operating circumstances of the alternator.

Protection for parallel operation

When an industrial installation has one or several generation equipments designed to operate in parallel with the supply authority network, it is advisable to provide a specific protection system.

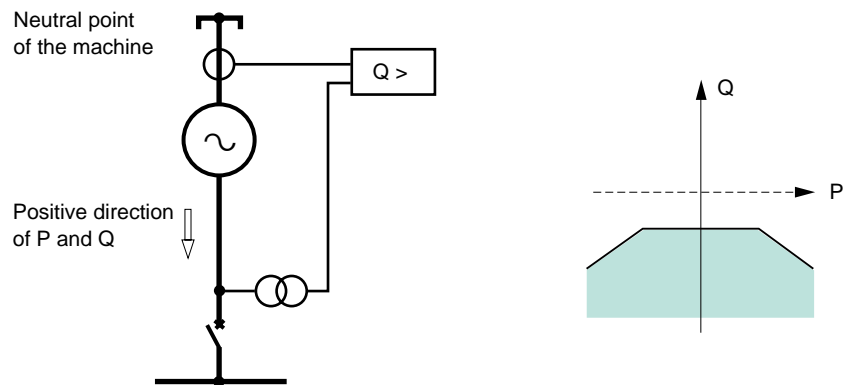

[fig. 28](#): Protection against excitation losses by a reactive reverse power relay.

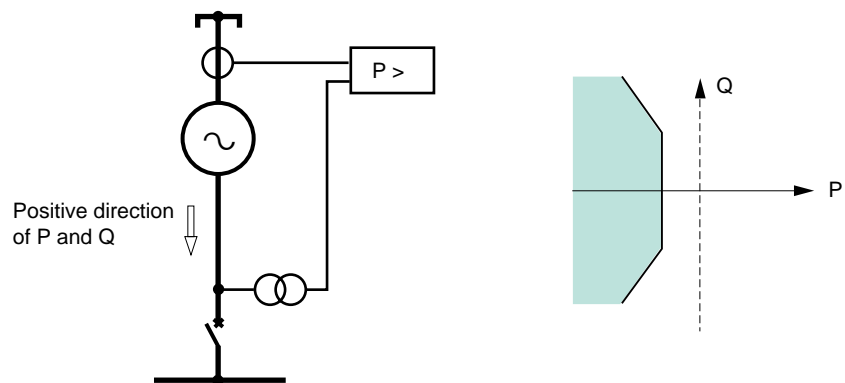

[fig. 29](#): Detection of motor operation, by an active reverse power relay.

This protection equipment has two objectives:

- ensuring the safety of the production unit's power station,
- ensuring the safety of the main network, which can be supplied from the industrial premise's power station.

This protection equipment is generally installed on the industrial network incomer circuit breaker, controlling its opening. It can also control the opening of a coupling circuit breaker between two parts of the installation.

One of the roles of the decoupling protection equipment is illustrated in **figure 30** : it involves **detecting a fault situated upstream of the industrial installation**, with the dual aim of:

- ensuring the safety of the network: cutting the supply to the fault,
- ensuring the safety of the alternator : avoiding the reclosing of the feeder to the source substation, performed without taking any account of the conditions of synchronisation, causing a dangerous coupling.

Fault detection is ensured by phase directional and earth fault protection equipment:

- earth fault directional protection detects the residual current created by phase to earth capacitance in the installation and / or that generated by the earthing of the power station,
- directional phase protection detects an upstream fault between phases.

Because it is directional, this protection equipment is insensitive to a fault situated within the industrial installation.

- Apart from directional protection equipment, a protection for parallel operation often comprises

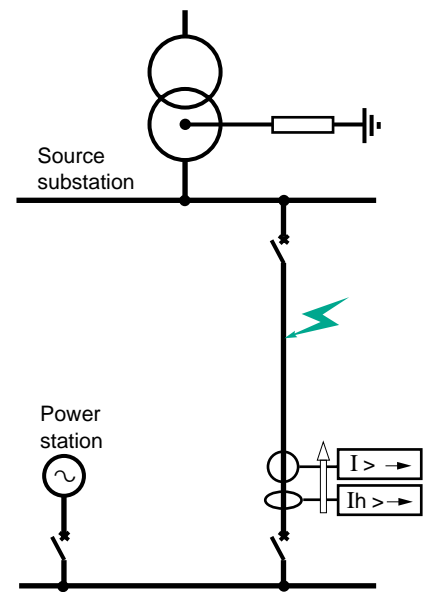

fig. 30: Example of decoupling protection equipment.

a rate of change of frequency relay (df/dt): the spurious increase in power demand at the power station, in the case of a loss of mains, causes a variation in generator frequency.

Voltage and frequency protection equipment can be requested by the supply authority in order to guarantee the quality of energy supplied by the private generation equipment.

Lastly, an active overpower protection system can also be installed in order to indicate an abnormal direction of power flow.

4 Use

4.1 Sizing of current and voltage transformers

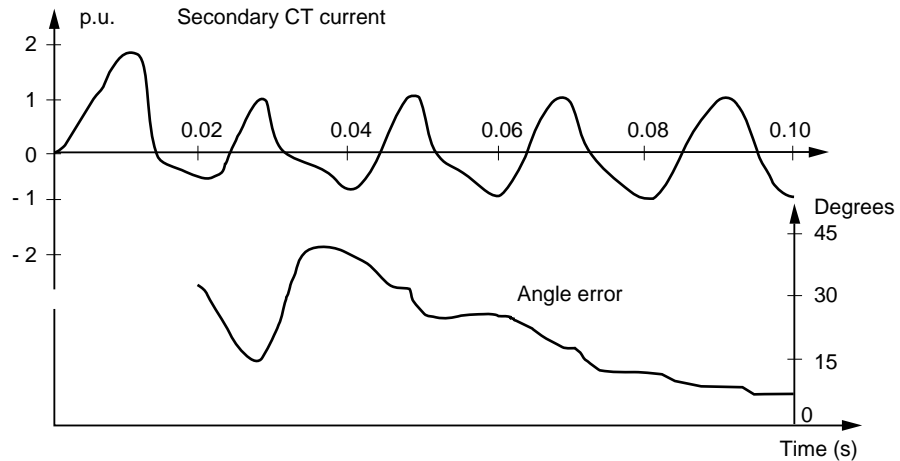

fig. 31: Angle error calculated under the following conditions:
 ■ the fault comprises an aperiodic component of 100% and a time constant of 40 ms;
 ■ the CT's saturation current is twice the short circuit current.

The choice of VT's (voltage transformers) does not pose any particular problem. VT's normally installed on distribution networks are either of class 0.5 or 1; they are perfectly suitable for the supply of directional protection equipment as long as the sum of the loads connected to them is neither greater than their rated burden, nor too low, in order to avoid risks of ferro-resonance.

CT's (current transformers) are more tricky to design for this purpose. Should they be under-designed and in the instance of a short circuit current having an aperiodic component with a high time constant, the CT's become saturated. This phenomenon causes an error in the phase current measurement during the transient, as shown in **figure 31**.

The current measured on the CT's secondary winding always leads the primary current.

Incorrect design of CT's can have two consequences:

- it may cause spurious tripping - a risk that decreases the longer the protection equipment's time delay,
 - it may cause delayed tripping - a risk that is independent of the selected time delay.
- The main factor influencing the protection equipment's behaviour is the phase displacement α between the short circuit current and the protection's tripping zone boundary line, as defined in **figure 32**.

In practice, if this angle α is greater than 45° (which is very often the case with the recommended settings), the design requirements for the CT are not so strict : choose the accuracy limit factor for the CT (as defined in «Cahier Technique» n° 164) to be greater than or equal to 0.3 times the value of the maximum short circuit current observed by the directional protection equipment.

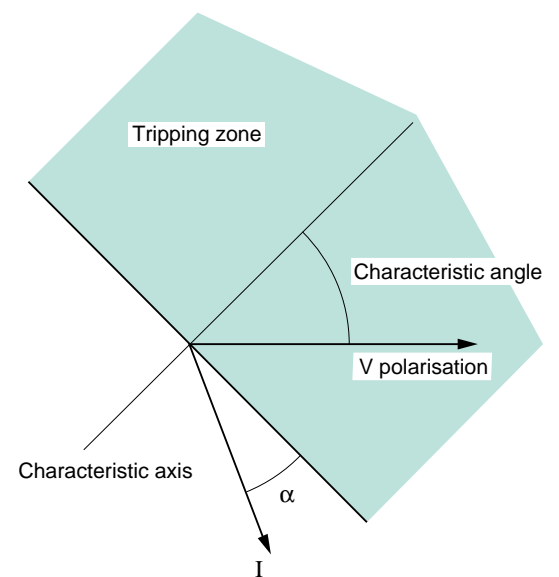

fig. 32: Definition of the angle α .

4.2 Selection between two or three phase protection

With analog technology, directional phase protection equipment is often single phase: it measures the current in one single phase. It is possible to equip one, two or all three phases with a relay.

With digital technology, several protection functions are integrated within one piece of equipment: directional phase protection equipment is most often two phase and sometimes three phase.

As a general rule, when detecting an abnormal transfer of power (protection of machines), the

phenomenon is balanced over the three phases and therefore a single phase relay is sufficient. When wanting to detect a short circuit between two phases, two phase directional protection equipment is sufficient : at least one of the two phases will be involved in the fault.

To detect a phase to earth fault, either three phase directional phase protection equipment or earthing protection equipment will be required. If the installation's neutral is directly earthed, the first solution is often best suited. For all other neutral point arrangements, choose the second one.

4.3 Protection of parallel connected transformers

Directional phase protection equipment may be preferred to differential protection equipment in order to protect two parallel connected transformers, especially if the two busbars are quite far apart (in practice it is impossible to wire the secondary circuits of CT's over more than a hundred or so metres).

The protection system to use in this case is shown in **figure 33**, taking care to follow the following setting recommendations:

- the instantaneous overcurrent protection equipment threshold is set to only detect faults on the transformer's primary circuit;
- primary-secondary inter-tripping;

- directional phase protection equipment set to only detect faults on the transformer's secondary circuit.

Depending on the neutral point on the transformer's secondary circuit, two variants appear:

- if the secondary neutral point is located on the busbars, earth fault directional protection is replaced by simple residual overcurrent protection;
- if each transformer has its own neutral point and if the secondary circuit busbars and the transformers are located within the same substation, restricted earth fault protection can be used in place of the earth fault directional protection.

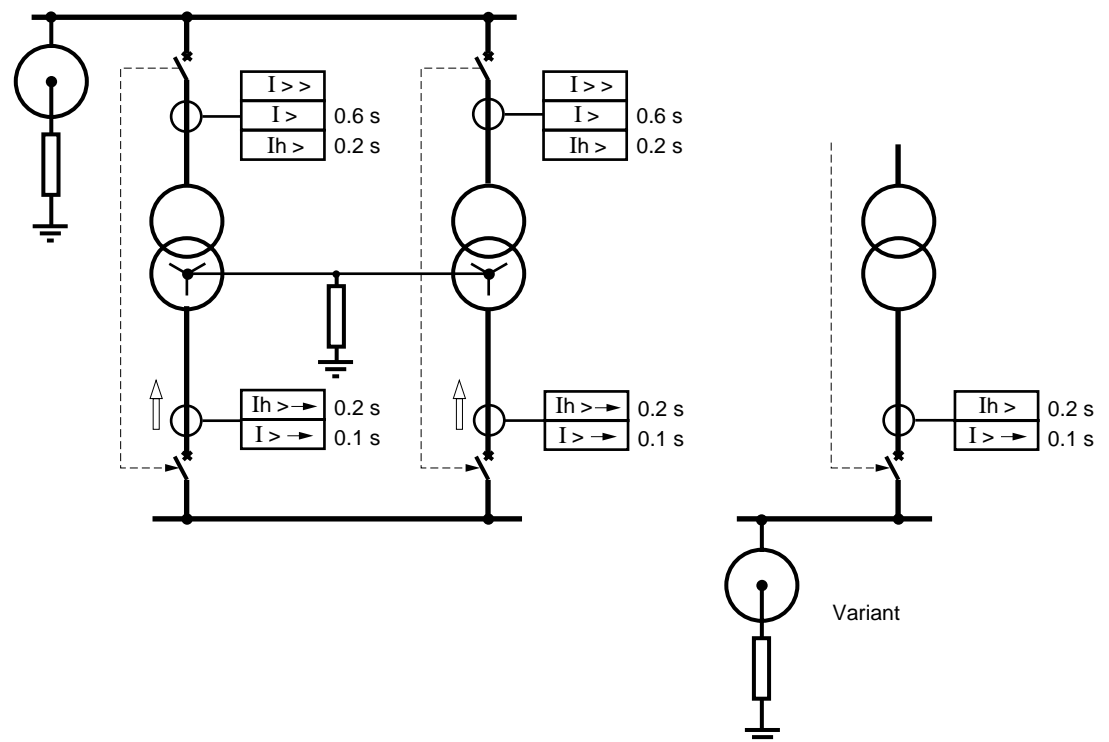

fig. 33: Protection layout for two parallel connected transformers.

5. developments and outlook

5.1 Developments in protection equipment technology

The generalisation of integrated and digital protection equipment makes directional protection equipment simple and relatively inexpensive to use. This type of protection equipment is therefore now seen as presenting an excellent opportunity to improve both the power transmitted through the network and the quality of service.

For example, two lines, one to provide power and the other to provide back-up, may now be operated in parallel using directional protection equipment.

Combining logical selectivity (ref. «Cahier Technique» n°2) and directional protection equipment enables systems to be designed that improve the dependability of the electrical power.

The appearance on the market of multiple-function relays (in other words ones combining all the protection functions plus the required control logic) that are dedicated to each application, simplifies the design and incorporation of the protection system (see [fig. 34](#)).



fig. 34: The SEPAM 2000, a multiple function digital relay enabling directional protection equipment to be used combined with logical selectivity.

5.2 Developments in sensors

The advent of digital protection equipment, requiring very little power for measurements, has enabled new sorts of sensors to be used. Rogowski coils (CT's without a core), because they do not become saturated, enable directional phase protection equipment to retain its measurement accuracy and to avoid angle errors whatever the fault. The problem of sizing the CT disappears.

These measurement reducers, comprising a large number of turns wound around a non-magnetic core, are described in «Cahier Technique» n°170.

Resistive voltage dividers, with their low cost and low space requirements, are installed in cubicles, near to the directional protection equipment : the voltage measurement cabling is much more reliable than when VT's are used: VT's are no longer a common failure mode of the protection system.

The development of sensors goes further to strengthen the interest of directional protection equipment, by improving performance levels and making them easier to incorporate.

5.3 In conclusion

Technological advances (digital protection equipment, new sensors, etc.), as well as logical selectivity make directional protection equipment easier to use.

Today, this high performance and easy to incorporate protection equipment is proving invaluable in improving the dependability of the

electrical power supply. It is increasingly being used to protect networks and machines, whether for phase to phase fault protection or for earthing fault protection.

Readers interested in more general information on the various types of protection equipment used in MV can refer to «Cahier Technique» n° 174.

